

No	P/N	Qty	Description
1	RA-BAS-0076	1	MA10-Torch-V3 Valve Control Arm Complete Assembly
2	RA-BAS-0077	1	MA10-Torch-V3 Shoe Control Arm Complete Assembly
3	RC-FAB-0176	1	MA10-Torch-V3 Agitation Handle
4	RC-GCM-0067	1	Thermometer - 16.5" Probe - Shock Proof Liquid Filled
5	RC-STR-0001	1	Propane Tank Ratchet Strap
6	RC-FAB-0147	1	Thermometer Guard - MA-V4
7	RC-FAB-0151	1	Lid Handle - MA-V4
8	RC-FAB-0143	1	Agitation Sweep Bar - MA-V4
9	RA-GCM-0015	1	MA Torch Complete Assembly
10	RA-BAS-0078	1	MA10-Torch-V3 Handle Bar Assembly
11	RC-FAB-0171	1	MA10-Torch-V3 Tank Shelf
12	RC-FAB-0133	1	Tank Spacer - MA-V4
13	RC-FAB-0101	1	Melter Lid Support Slider
14	RC-FAB-0169	1	MA10Torch-V3 Kettle Body
15	RC-LCH-0001	1	Latch - 10 Gallon Kettle
16	RA-WHL-0026	2	Rear Wheel Assembly with Bearings - Melter Applicator - V2
17	RA-BAS-0071	1	Valve and Shoe Sub Asy
18	RA-WHL-0025	1	Front Caster Assembly

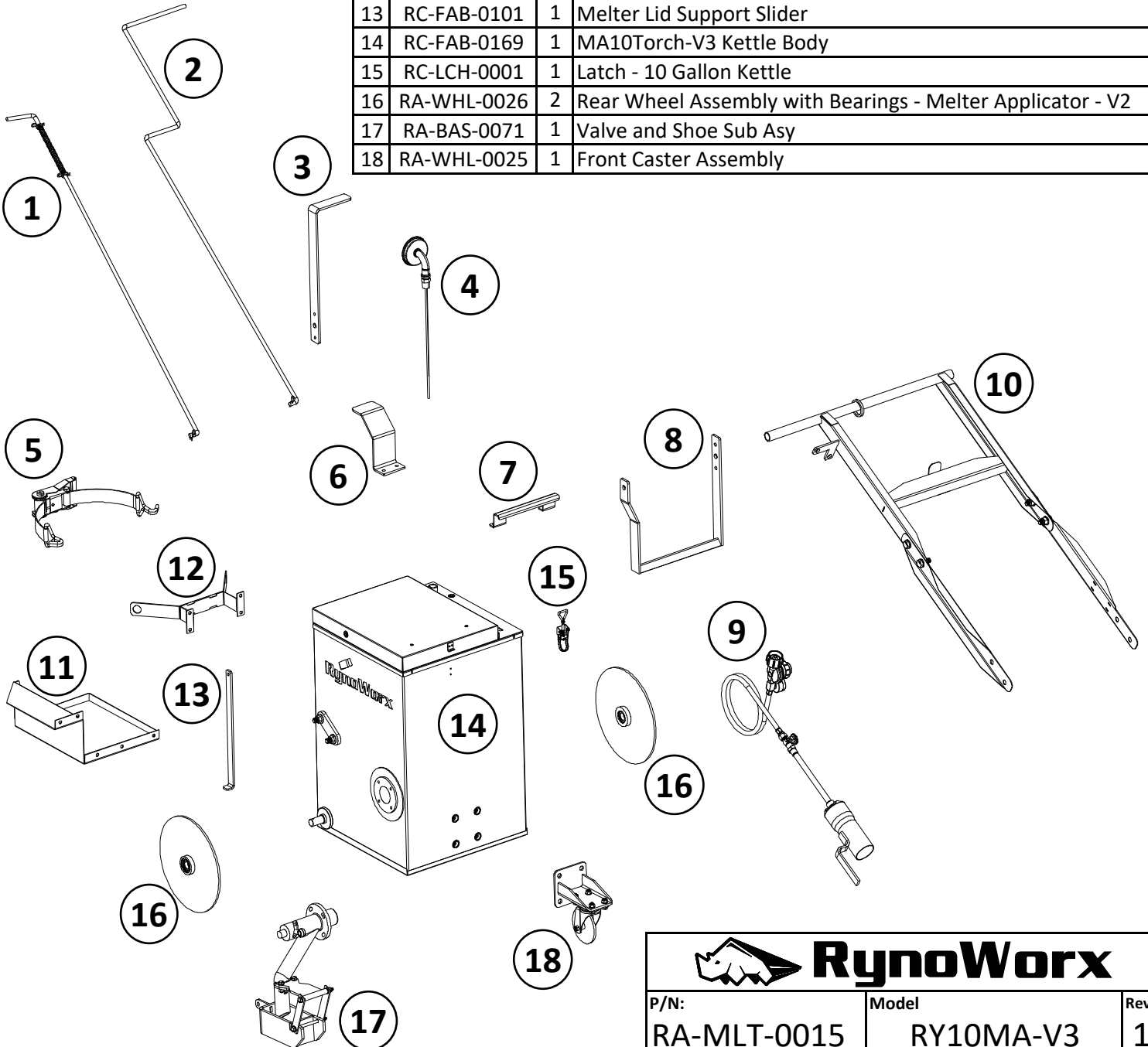



RynoWorx

P/N: RA-MLT-0015	Model RY10MA-V3	Rev: 1
---------------------	--------------------	-----------

Description:
RY10MA - 10 Gallon Torch Fired Melter Applicator - Complete Assembly - Version 3

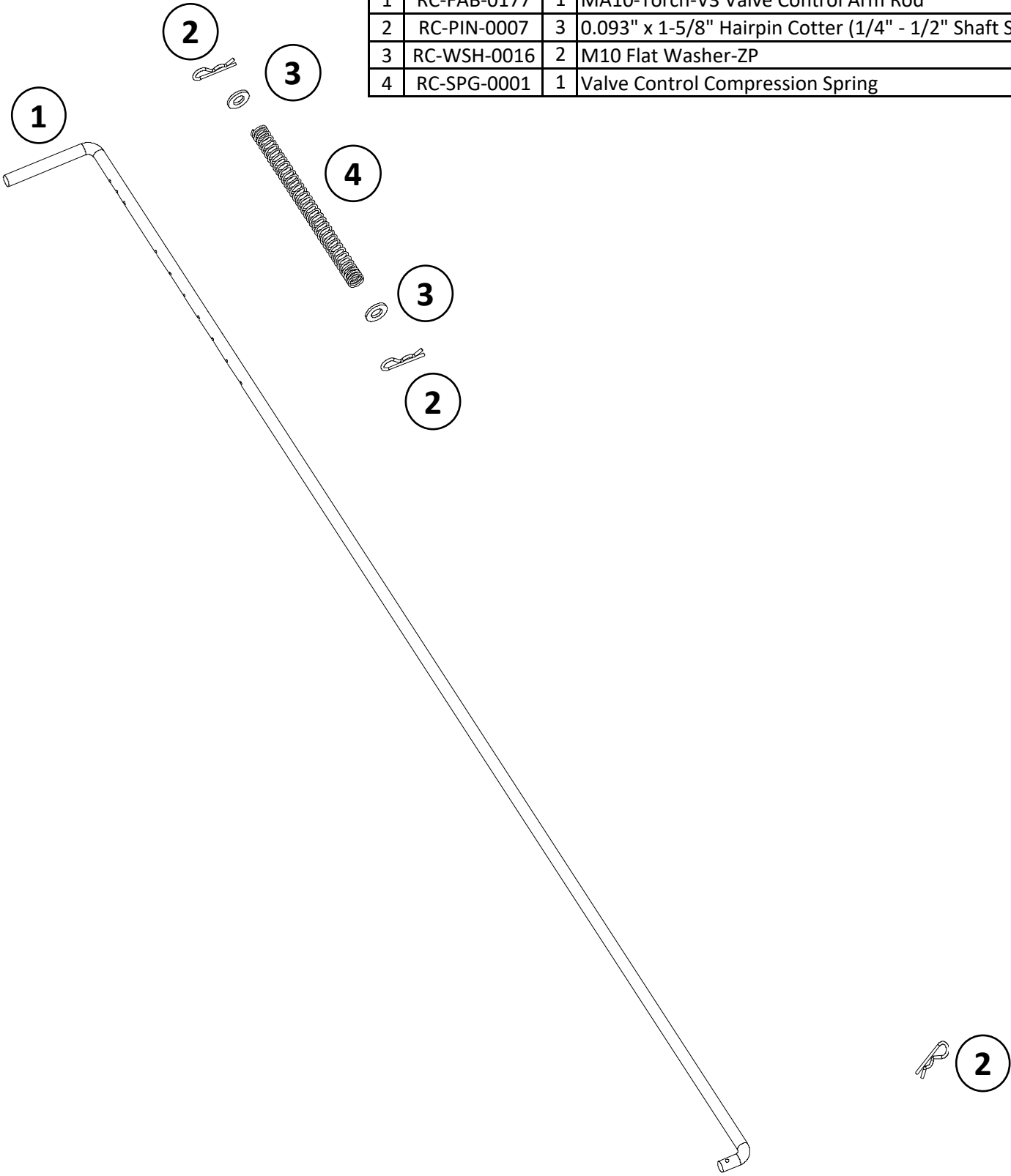
No	P/N	Qty	Description
1	RC-FAB-0177	1	MA10-Torch-V3 Valve Control Arm Rod
2	RC-PIN-0007	3	0.093" x 1-5/8" Hairpin Cotter (1/4" - 1/2" Shaft Size) - ZP
3	RC-WSH-0016	2	M10 Flat Washer-ZP
4	RC-SPG-0001	1	Valve Control Compression Spring



 RynoWorx	
P/N: RA-BAS-0076	Rev: 1
Description: MA10-Torch-V3 Valve Control Arm Complete Assembly	

No	P/N	Qty	Description
1	RC-FAB-0178	1	MA10-Torch-V3 Shoe Control Arm Rod
2	RC-PIN-0007	1	0.093" x 1-5/8" Hairpin Cotter (1/4" - 1/2" Shaft Size) - ZP

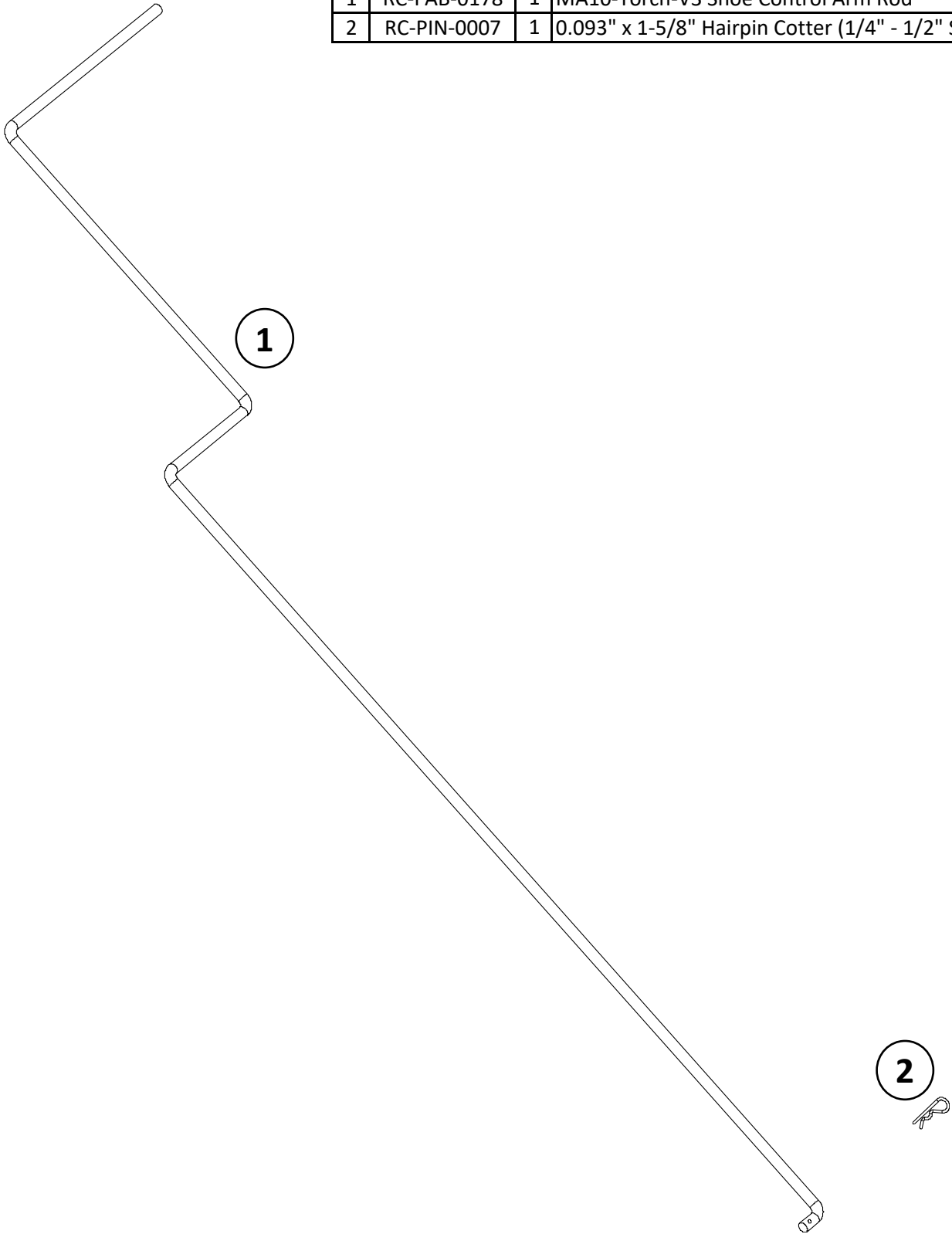

RynoWorx

P/N: RA-BAS-0077	Rev: 1
----------------------------	------------------

Description:
MA10-Torch-V3 Shoe Control Arm Complete Assembly

No	P/N	Qty	Description
1	RC-GCM-0016	1	Torch for Melter Applicator with Valve
2	RC-GCM-0068	1	Regulator and Hose - 0 - 30 Psi with Pressure Gauge (3 m)

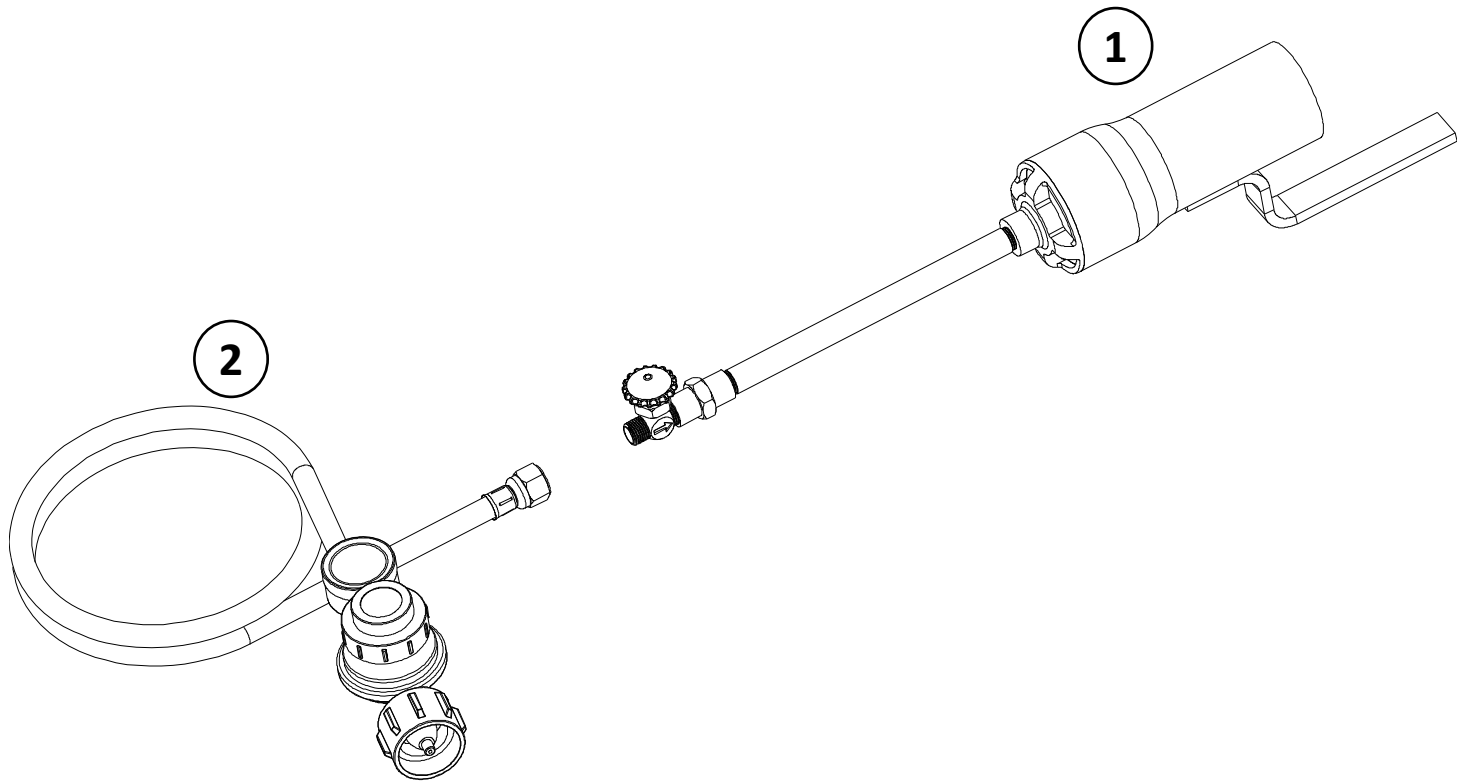

RynoWorx

P/N: RA-GCM-0015	Rev: 1
---------------------	-----------

Description:
MA Torch Complete Assembly

No	P/N	Qty	Description
1	RC-FAB-0170	1	MA10-Torch-V3 Upper Handle Bars
2	RK-FAS-0076	1	Fastener Kit - Handle Bars
3	RC-FAB-0179	1	MA10-Torch-V3 Lower Handle Bar Left
4	RC-FAB-0180	1	MA10-Torch-V3 Lower Handle Bar Right

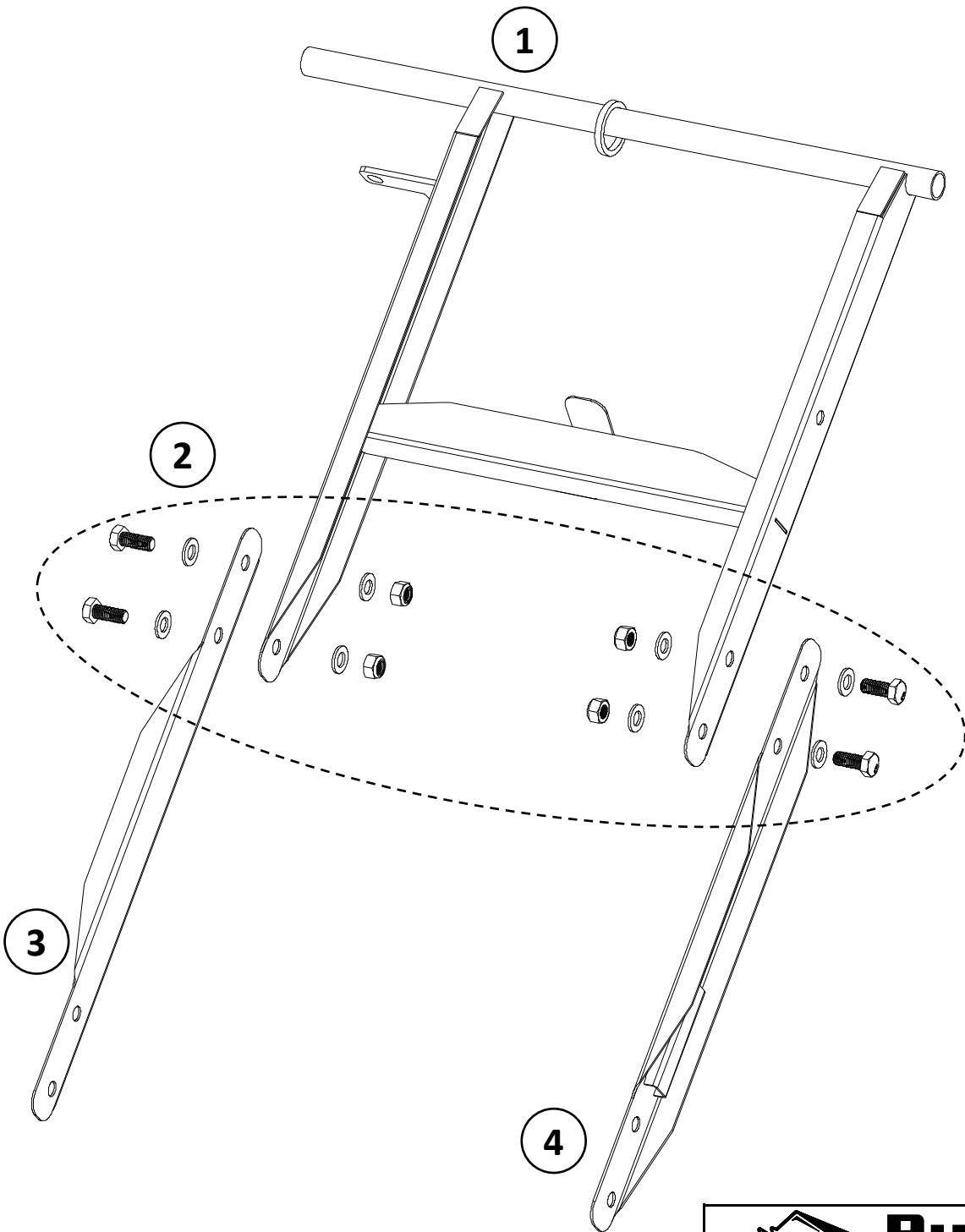

 RynoWorx	
P/N:	Rev:
RA-BAS-0078	1
Description:	
MA10-Torch-V3 Handle Bar Assembly	

No	P/N	Qty	Description
1	RC-RNG-0001	1	Internal Retaining Ring for 45 mm ID
2	RC-BRG-0001	2	Bearing, Rear Wheel, Melter Applicator
3	RC-WHL-0012	1	Rear Wheel - Melter Applicator - (Bearing Style)

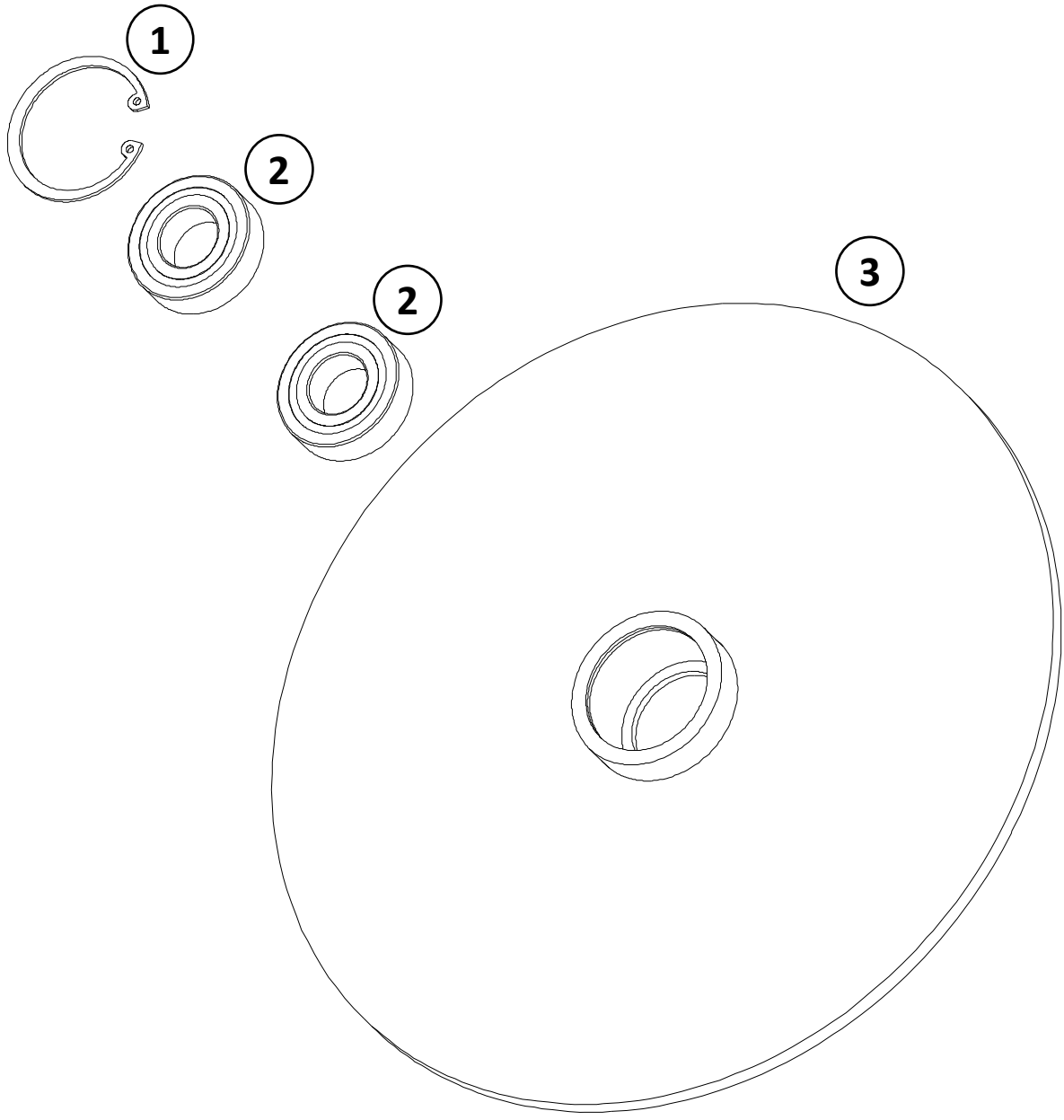

RynoWorx

P/N: RA-WHL-0026	Rev: 1
Description: Rear Wheel Assembly with Bearings - Melter Applicator - V2	

No	P/N	Qty	Description
1	RA-VLV-0018	1	MA Draw Valve - Complete Assembly
2	RK-FAS-0064	1	Fastener Kit - Shoe Mount
3	RA-BAS-0057	1	Shoe Assembly - MA-V4

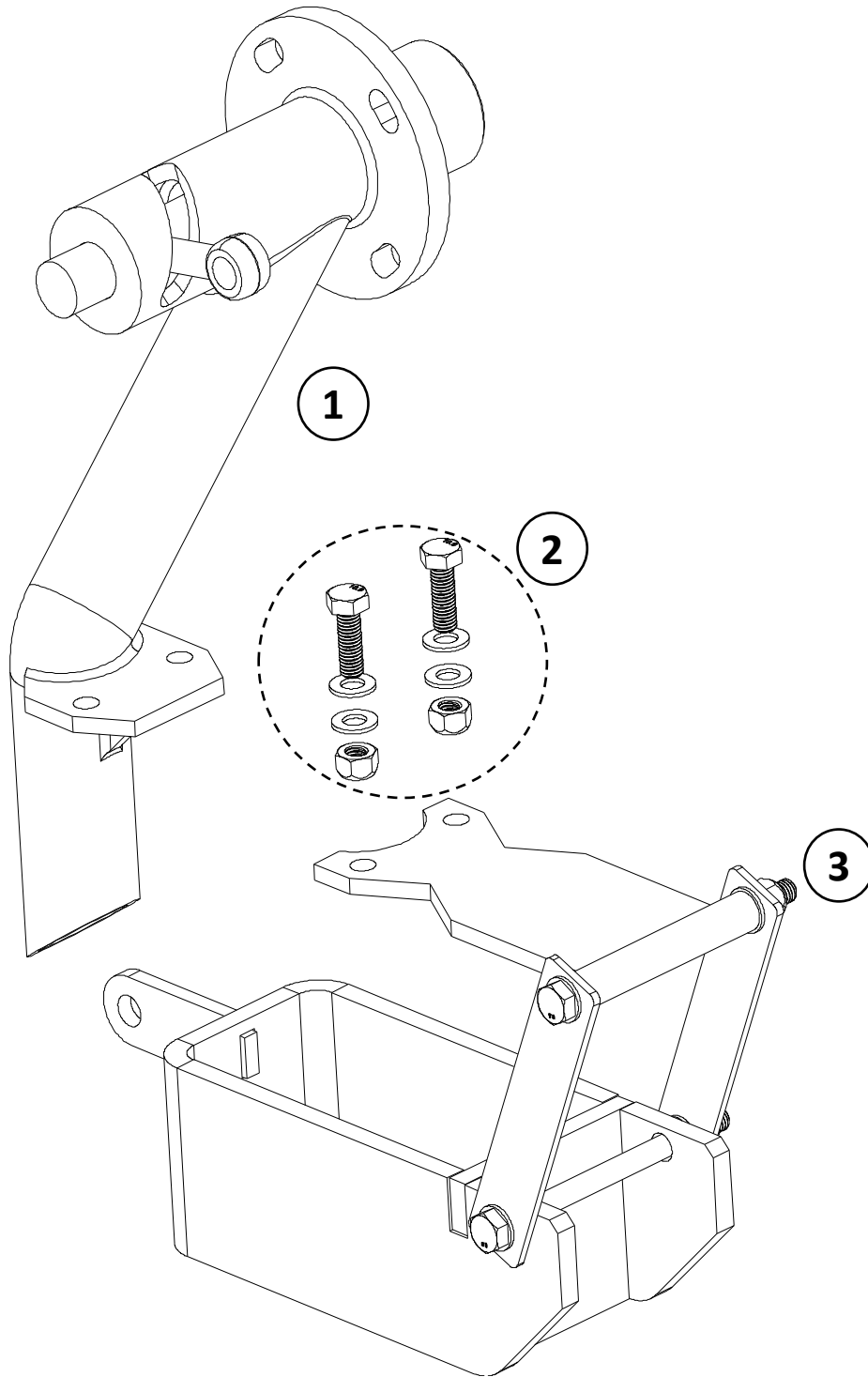

RynoWorx

P/N:
RA-BAS-0071

Rev:
2

Description:
Valve and Shoe Sub Asy

No	P/N	Qty	Description
1	RC-VLV-0016	1	MA Draw Valve - Body
2	RC-VLV-0017	1	MA Draw Valve - Stem
3	RC-FAB-0155	1	MA Draw Valve Rod End

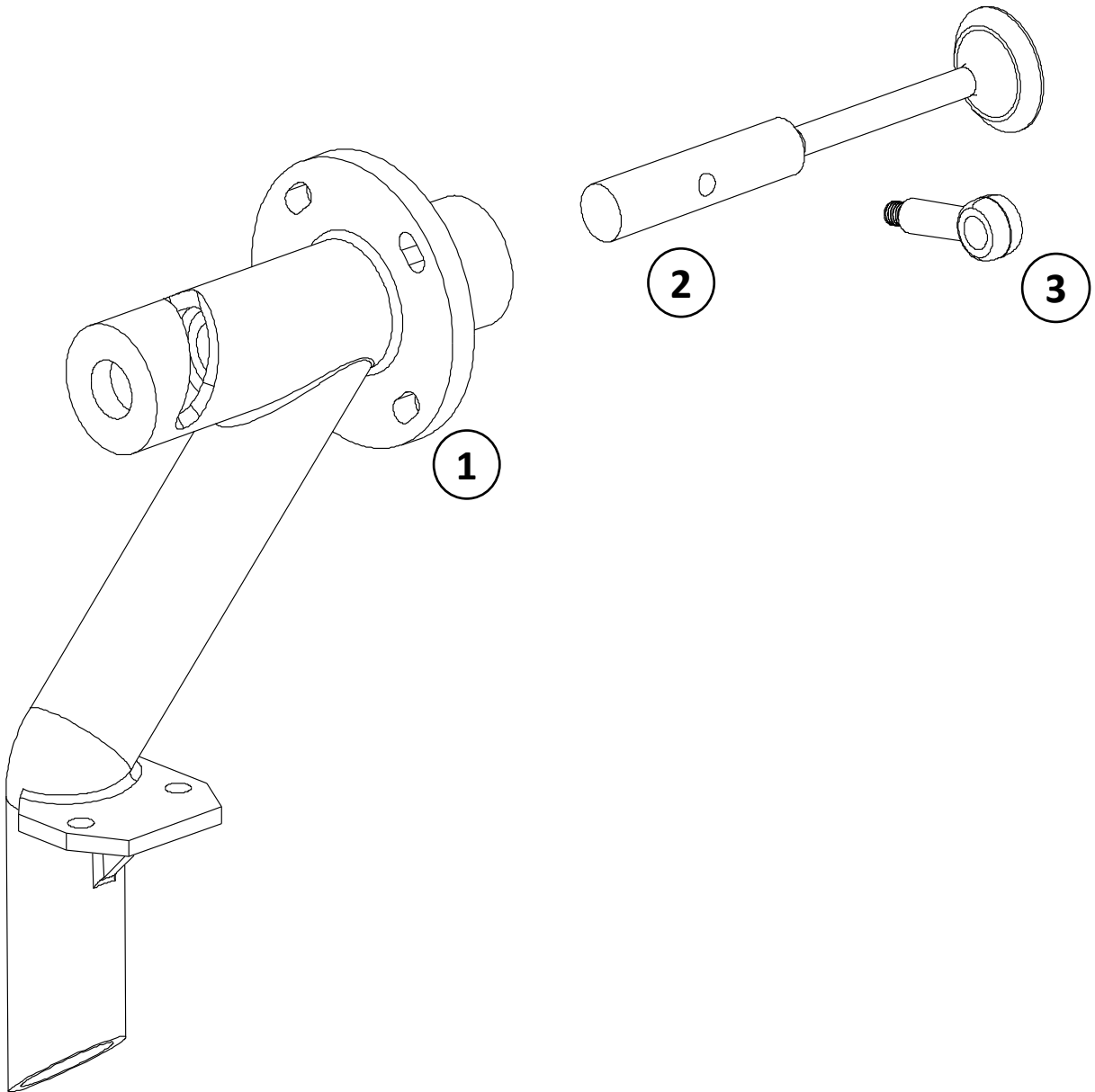

RynoWorx

P/N:

RA-VLV-0018

Description:

MA Draw Valve - Complete Assembly

No	P/N	Qty	Description
1	RC-FAB-0175	1	Shoe - Draw Valve - Version 2
2	RC-FAB-0137	2	Shoe Linkage - MA-V4
3	RC-FAB-0174	1	Shoe Mount Flange - Version 2
4	RK-FAS-0075	1	Fastener Kit - Shoe Hinge

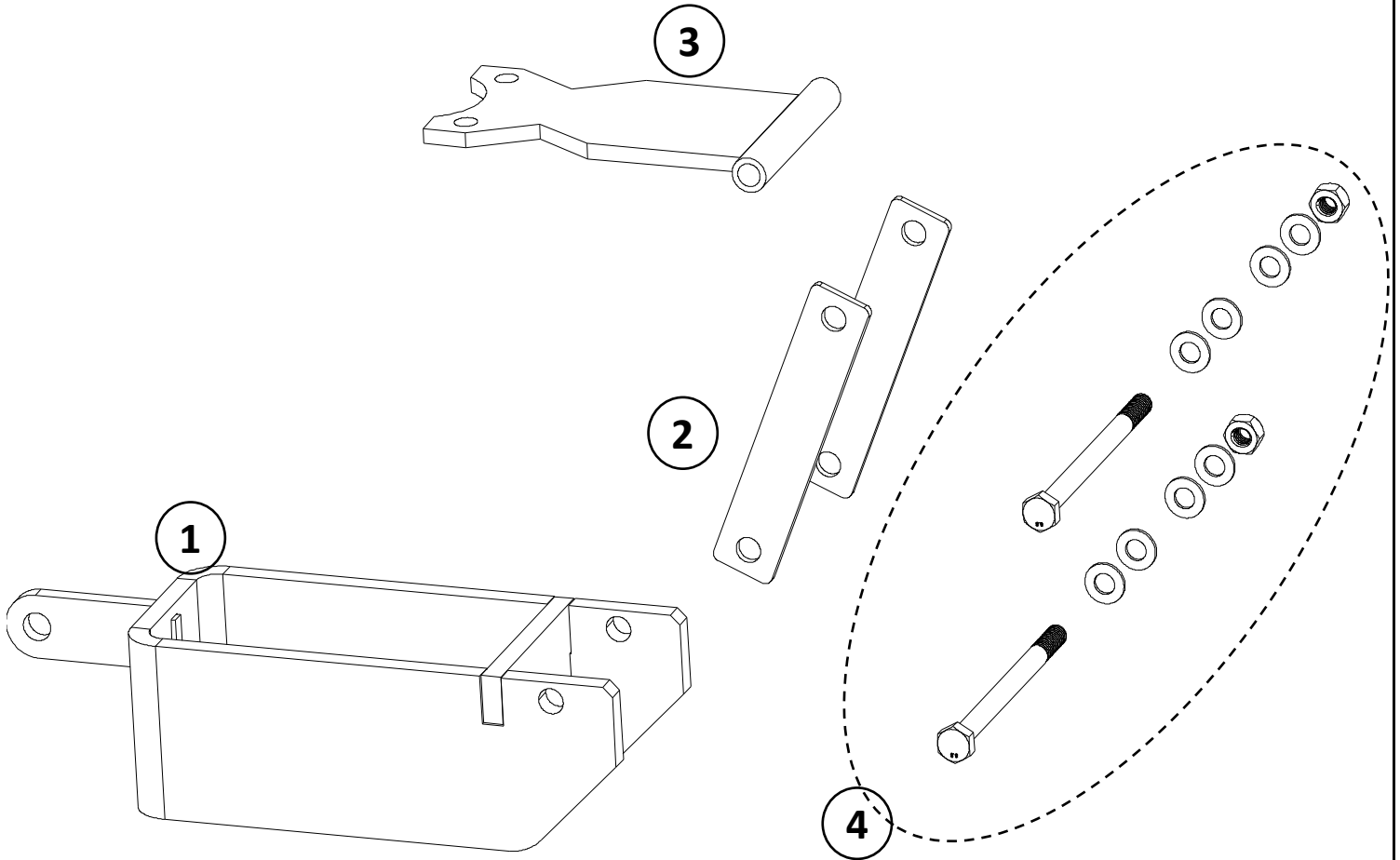

RynoWorx

P/N:
RA-BAS-0057

Rev:
2

Description:
Shoe Assembly - MA-V4

No	P/N	Qty	Description
1	RC-FAB-0131	1	Front Caster Bracket - MA-V4
2	RA-WHL-0005	1	Front Caster Assembly - 4 Bolt Style
3	RK-FAS-0082	1	Fastener Kit - Caster Bracket Pro

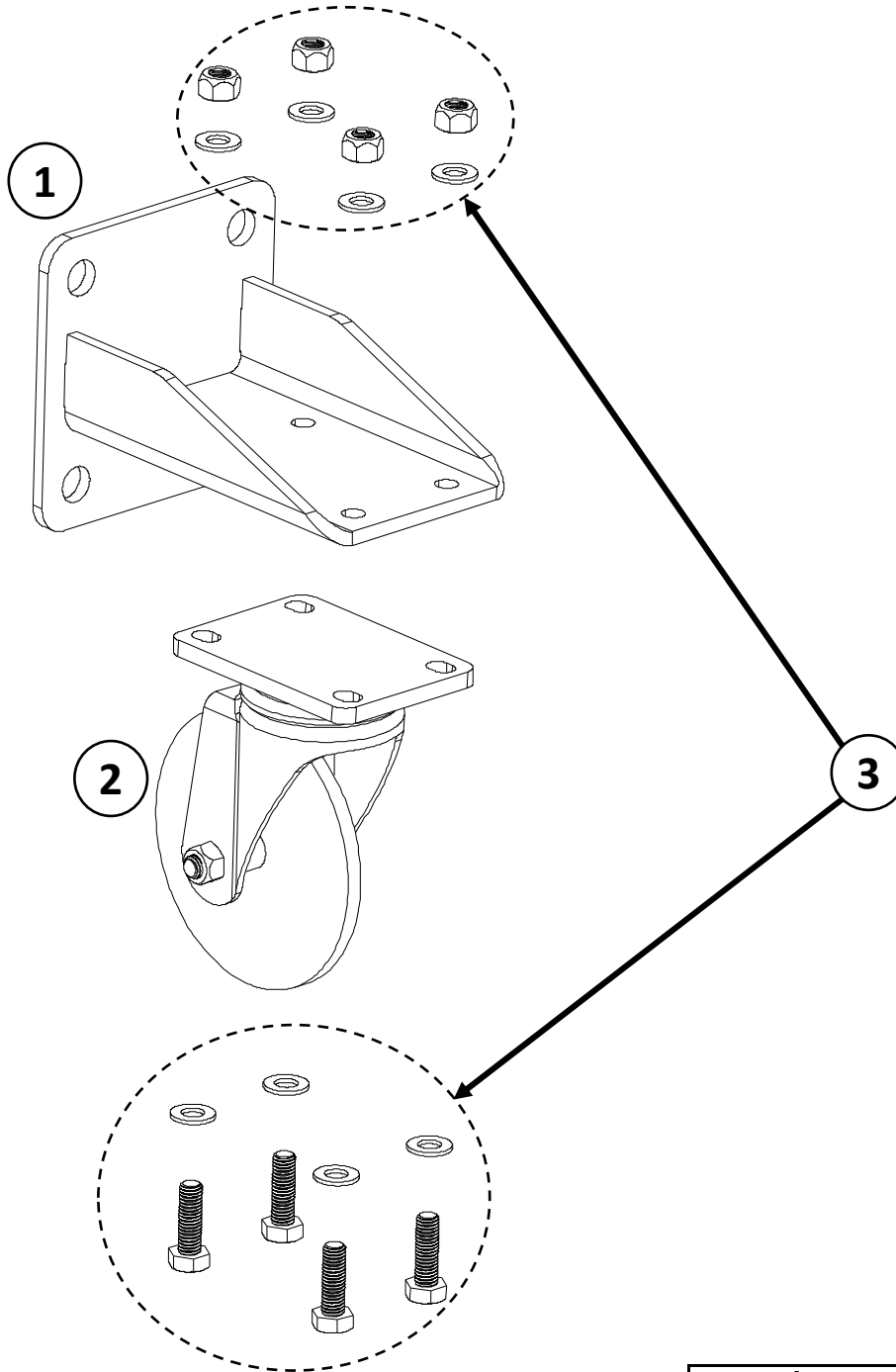

 RynoWorx	
P/N: RA-WHL-0025	Rev: 1
Description: Pro Front Caster Assembly	

No	P/N	Qty	Description
1	RC-WHL-0014	1	4 Bolt Caster Swivel
2	RC-WHL-0013	1	Wheel for Front Caster
3	RK-FAS-0033	1	Fastener Kit - Caster Wheel Axle

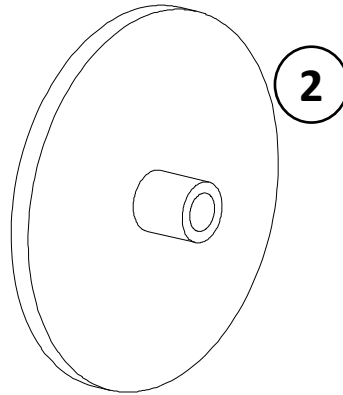
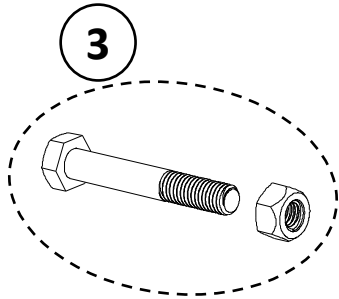
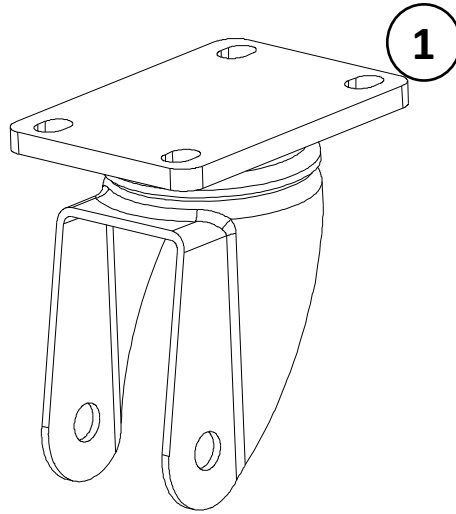

RynoWorx

P/N: RA-WHL-0005	Rev: 1
----------------------------	------------------

Description:
Front Caster Assembly - 4 Bolt Style