



# RynoWorx®



# R-SERIES MINI INFRARED ASPHALT HEATERS

REVISION 001  
JANUARY 2024

# TABLE OF CONTENTS

SAFETY ..... 3

R2-IR DIMENSIONS ..... 4

R2-IR ASSEMBLY ..... 5

R2-IR REGULATOR ..... 9

R3-IR DIMENSIONS ..... 10

R3-IR ASSEMBLY ..... 11

R3-150 HINGE KIT ..... 15

R4-IR DIMENSIONS ..... 16

R4-IR ASSEMBLY ..... 17

VENTURI ASSEMBLY ..... 21

R4-IR / R3-IR REGULATOR ..... 22

CASTER WITH BREAK ..... 23

CASTER NO BREAK ..... 24

PRODUCT SAFETY - REFRACTORY CERAMIC ..... 25

IR HEATER OPERATION ..... 27

IR HEATER CARTRIDGE REPLACEMENT ..... 31

VENTURI MAINTENANCE ..... 33

TROUBLESHOOTING ..... 34

IR REPAIR FAQ ..... 35

RYNOWORX CONTACT INFORMATION ..... 38



**WARNING: ALWAYS READ AND UNDERSTAND THIS OPERATIONS MANUAL BEFORE OPERATING THE HEATER OR SERVICING YOUR HEATER!**

**DO NOT** run heater in an enclosed area. Exhaust gases contain carbon monoxide, an odourless and deadly poison. This equipment is designed for outdoor use only.

Be sure to always wear personal protective equipment when operating this equipment.

Improper assembly may be dangerous. Please follow the assembly instructions in this manual. Make sure all parts are assembled and hardware is fully tightened before using. Make sure that there are no leaks in the liquid propane cylinder connections or lines.

**DO NOT** operate the equipment if a gas leak is present. (Check for leaks and connections with every use)

**DO NOT** attempt to disconnect the gas regulator from the tank or any gas fitting while the equipment is in use.

A dented or rusty propane tank may be hazardous and should be checked by your propane supplier. Do not use a propane tank with a damaged valve.

Ensure that your propane cylinder is within its expiry date for your local jurisdiction. If the tank has expired it must be properly re-qualified to continue using.

**DO NOT** store spare propane cylinders within 10 feet (3m) of this equipment.

**DO NOT** store or use gasoline or other flammable liquids or vapors within 25 feet (8m) of this equipment.

Before servicing, make sure the unit is fully cooled and the propane cylinder is disconnected.

Only genuine RynoWorx replacement parts should be used for any replacements or repairs. Do not attempt to modify or alter this product in any way.

**DO NOT** attempt to make any repairs to gas carrying, gas burning, igniter components or structural components. Your actions, if you fail to follow this warning, may cause a fire, an explosion, or structural failure resulting in serious personal injury or death as well as damage to property.

Failure to follow these instructions could result in fire or explosion which could cause property damage, personal injury or death.

**DO NOT** operate the heater while performing any maintenance.

**DO NOT** leave machine unattended while operating.

**DO NOT** park machine on a steep grade or slope.

**DO NOT** smoke while operating the heater.

**DO NOT** place hand under heater while operating for any length of time.

**DO NOT** operate the heater near an accumulation of grass, leaves or other combustible material.

**DO NOT** point torch at ceramic when lighting.

# R2-IR DIMENSIONS

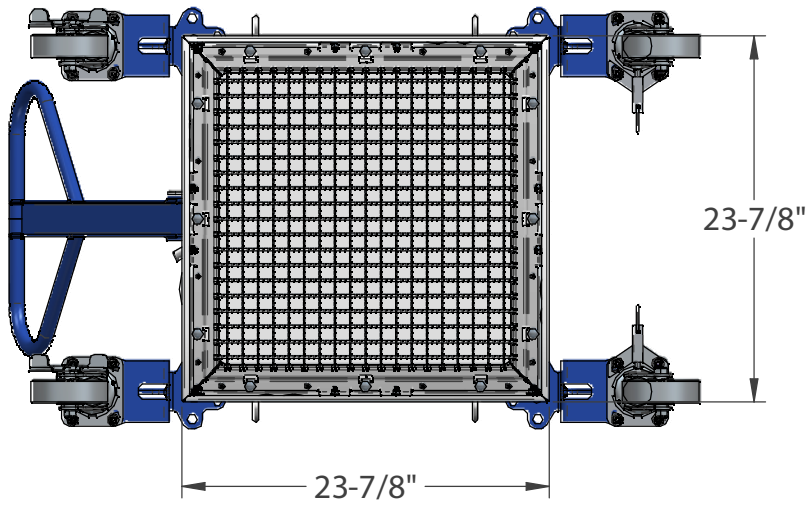
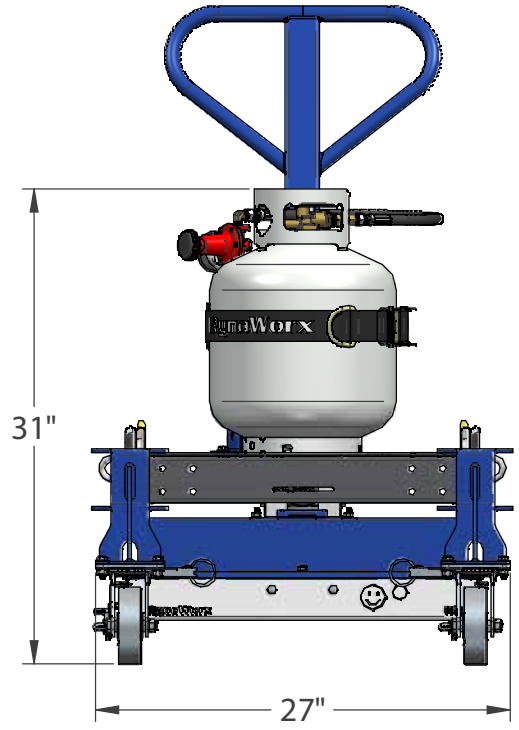
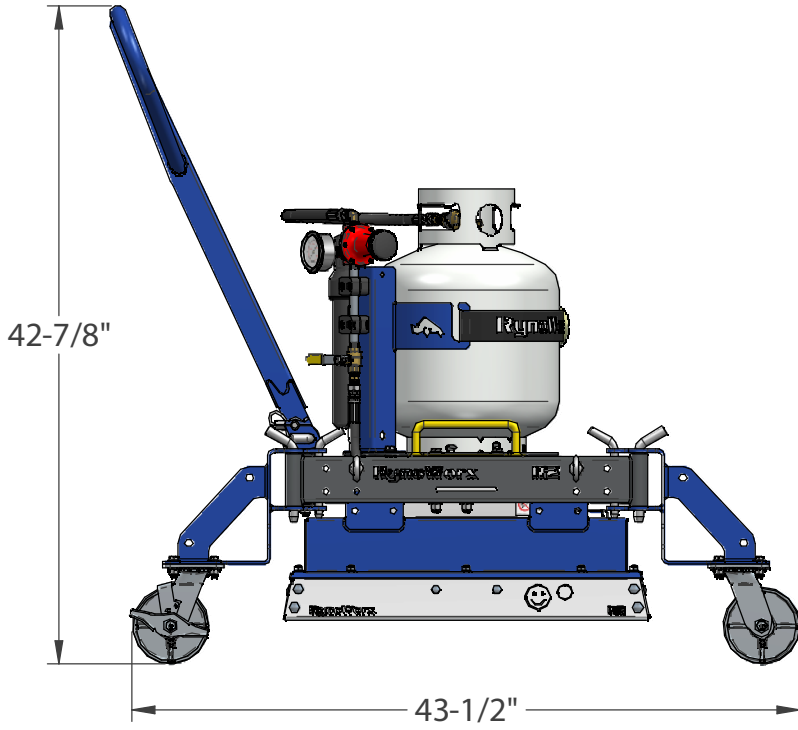

# R2-IR ASSEMBLY

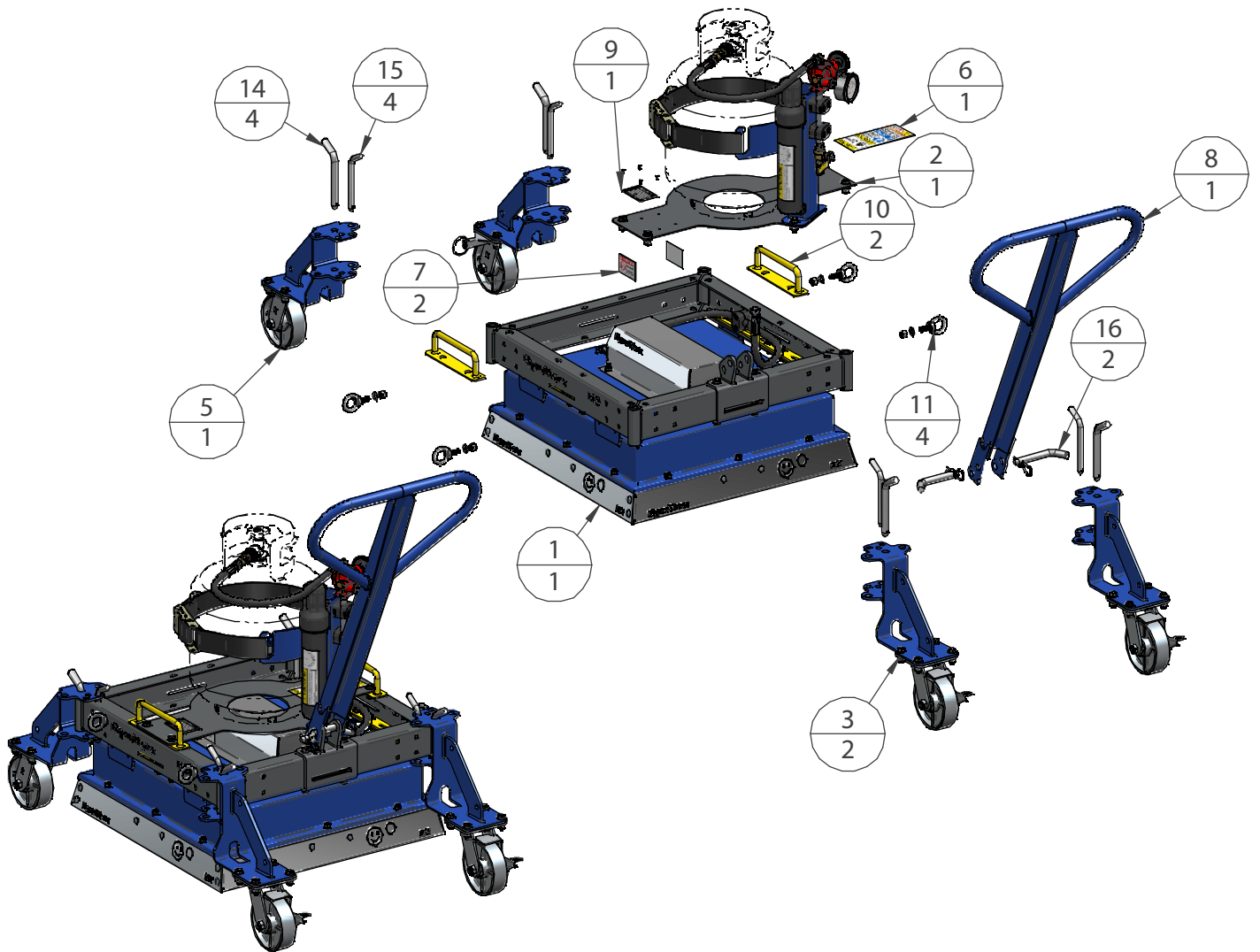

# R2-IR ASSEMBLY

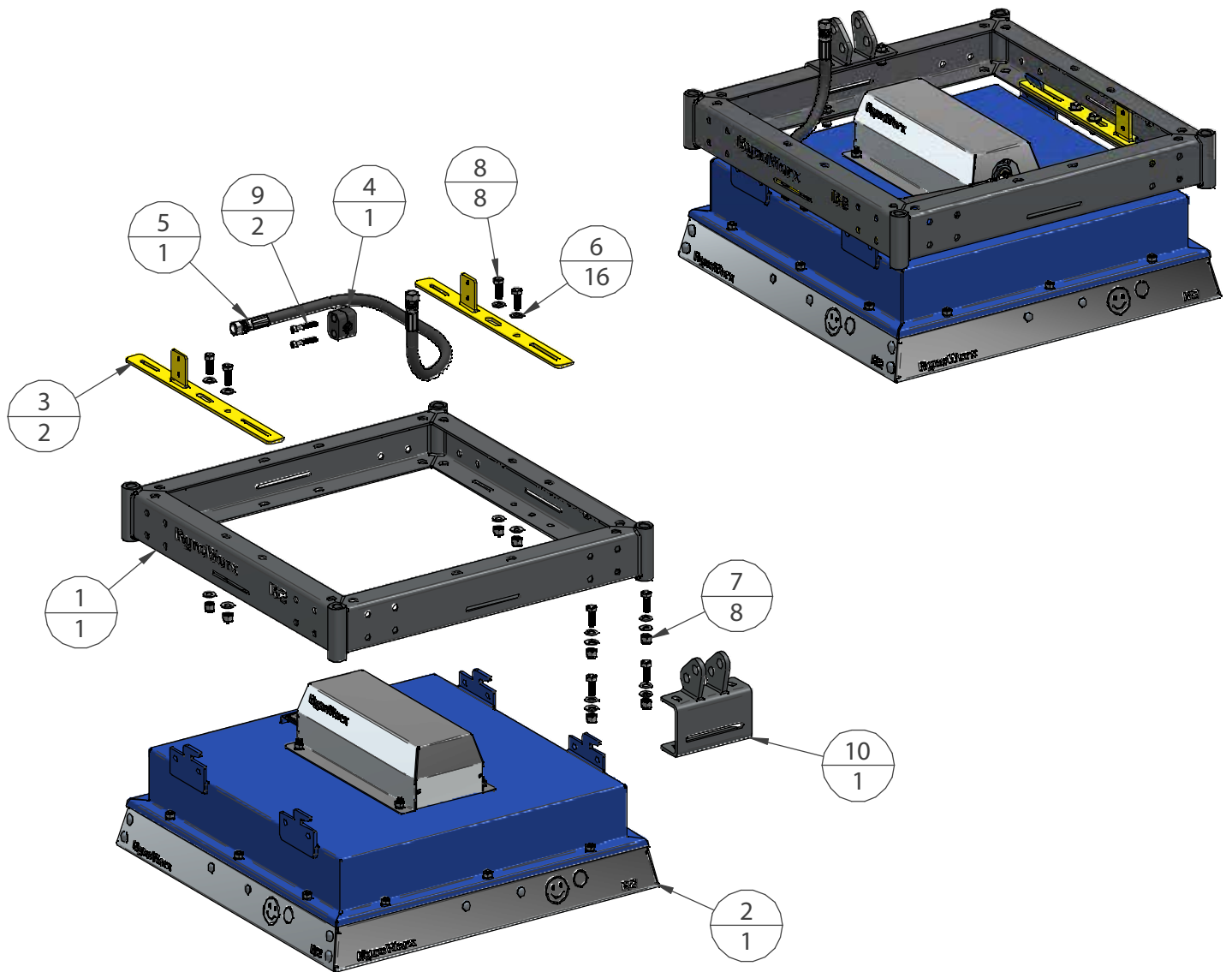

# R2-IR ASSEMBLY

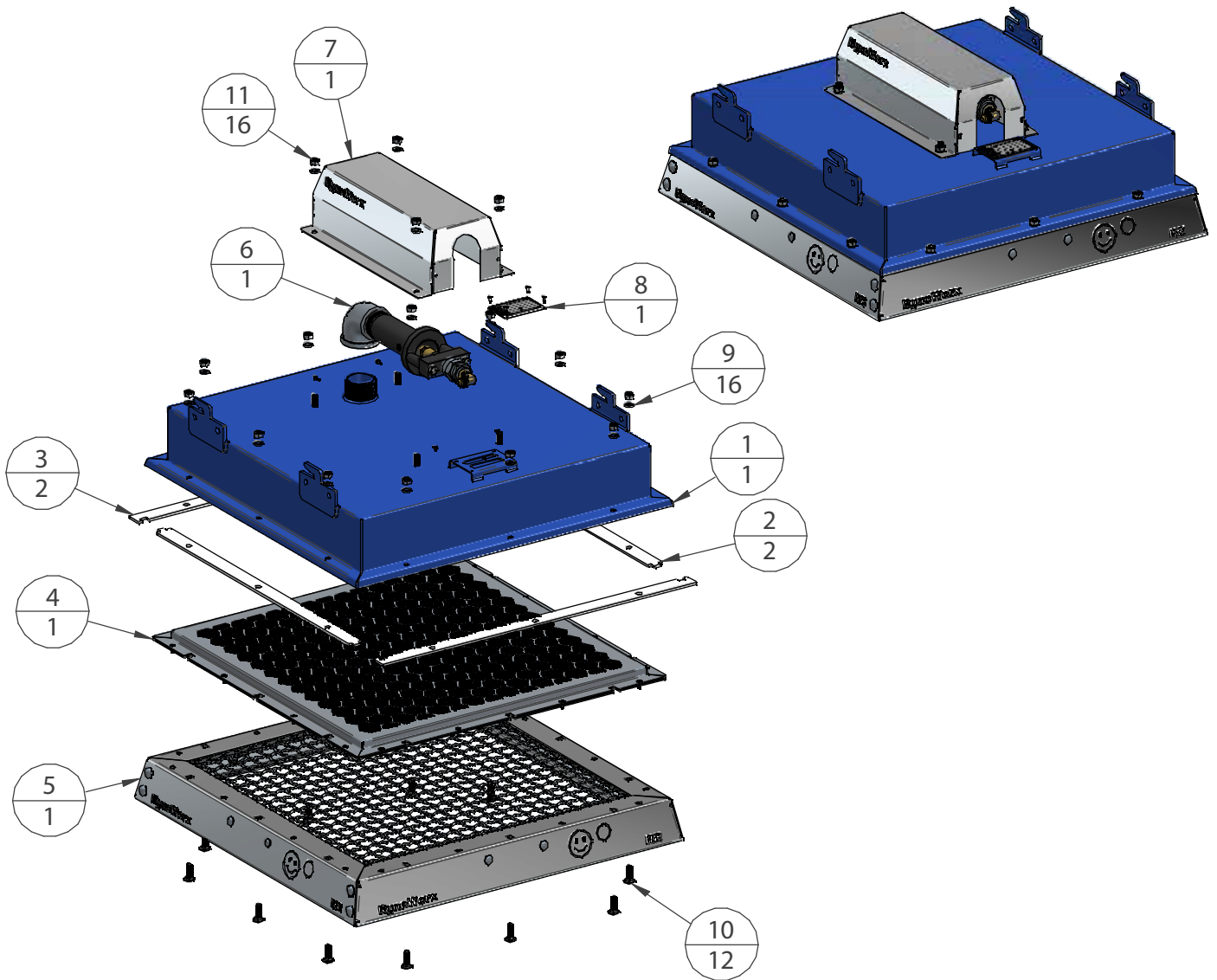

# R2-IR ASSEMBLY

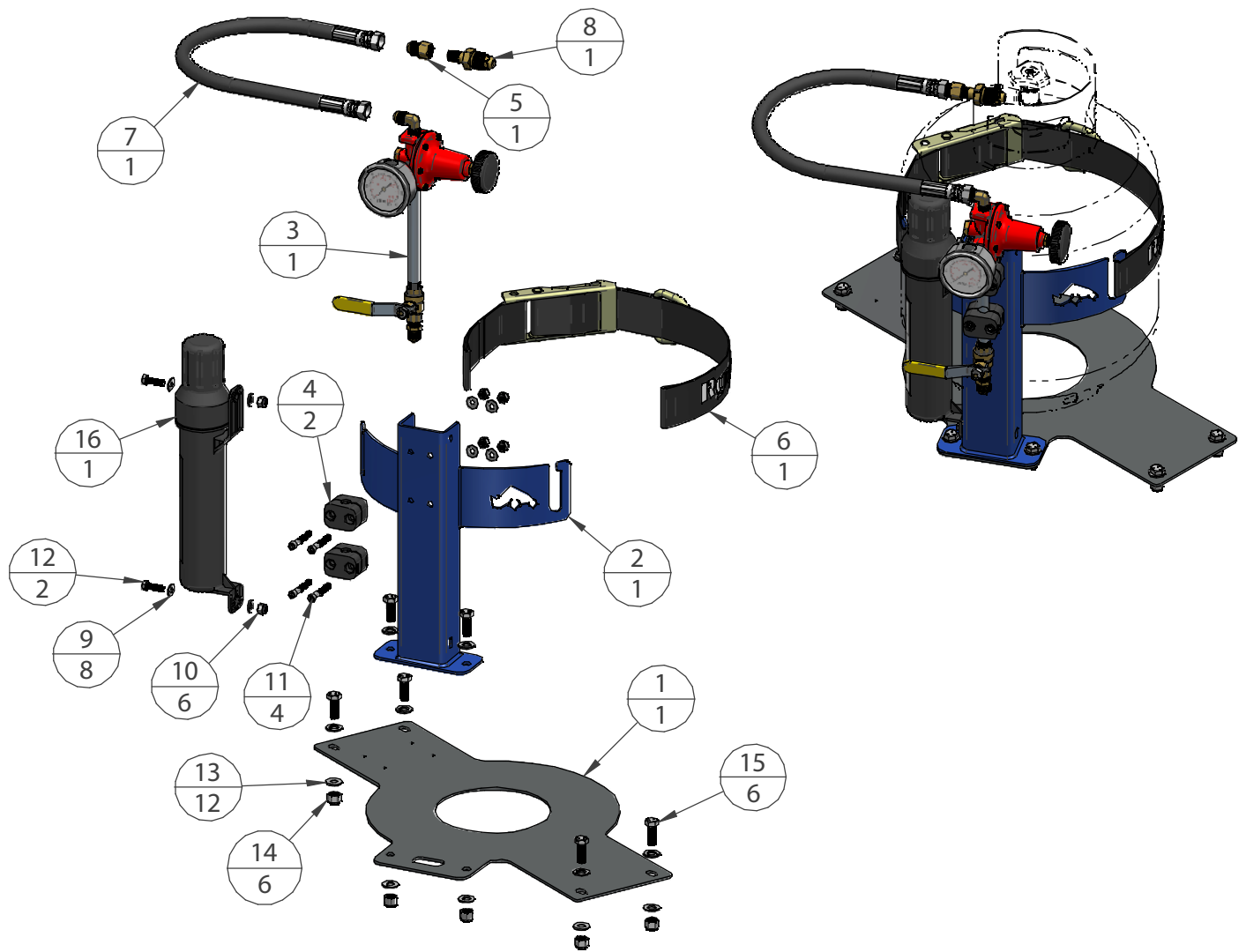



# R2-IR REGULATOR

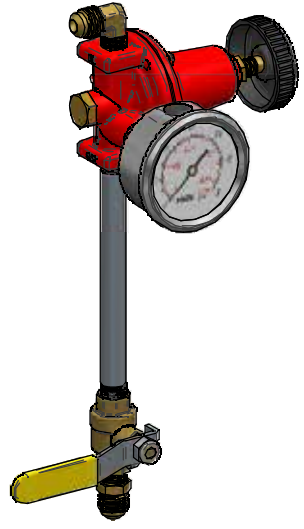
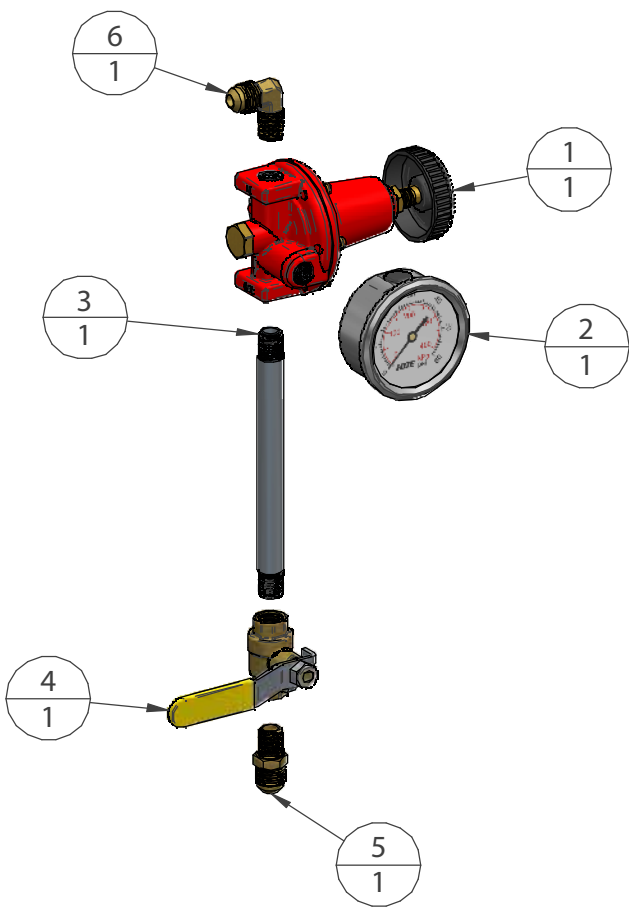

# R3-IR DIMENSIONS

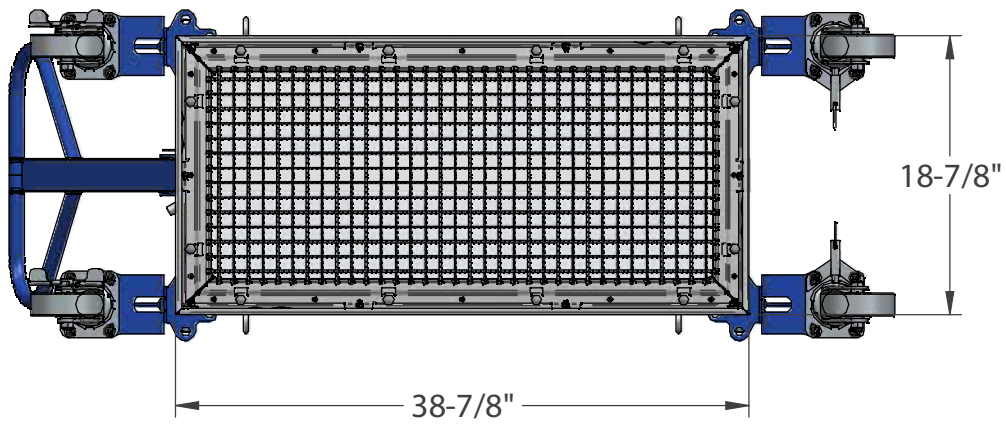
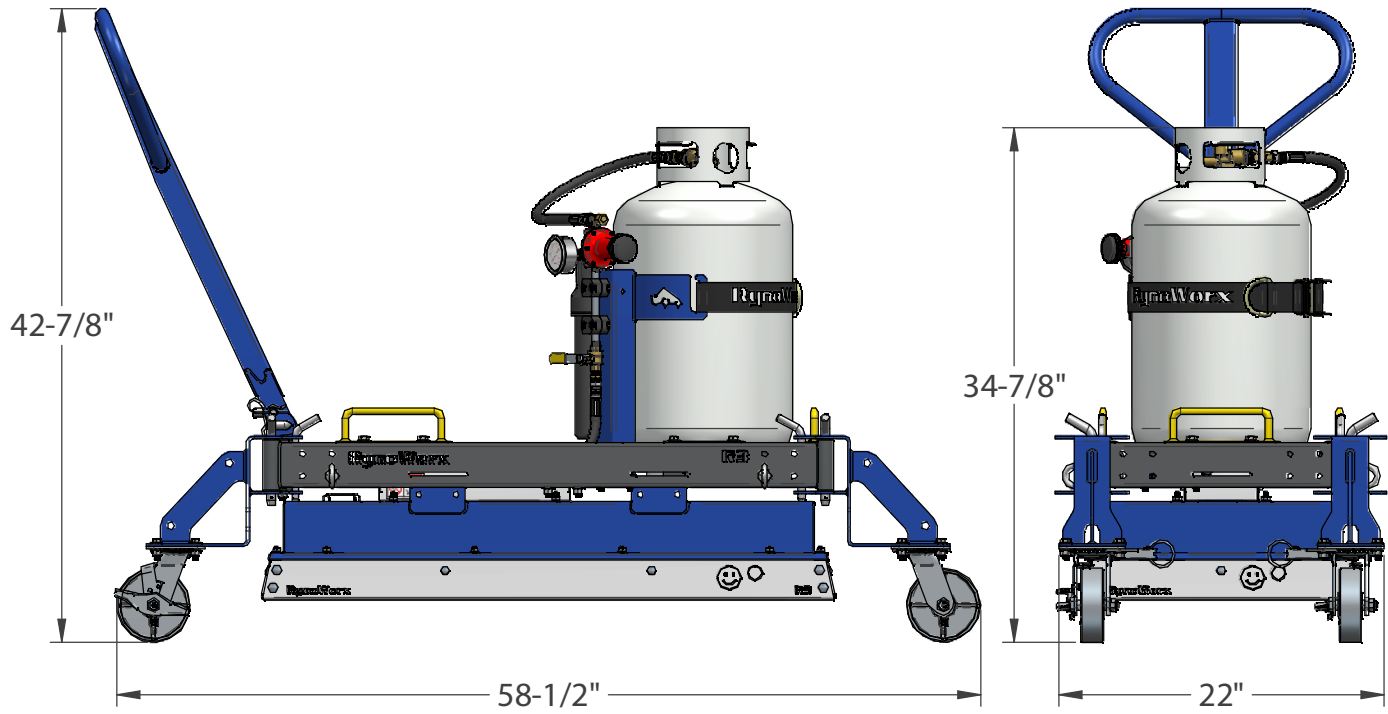

# R3-IR ASSEMBLY

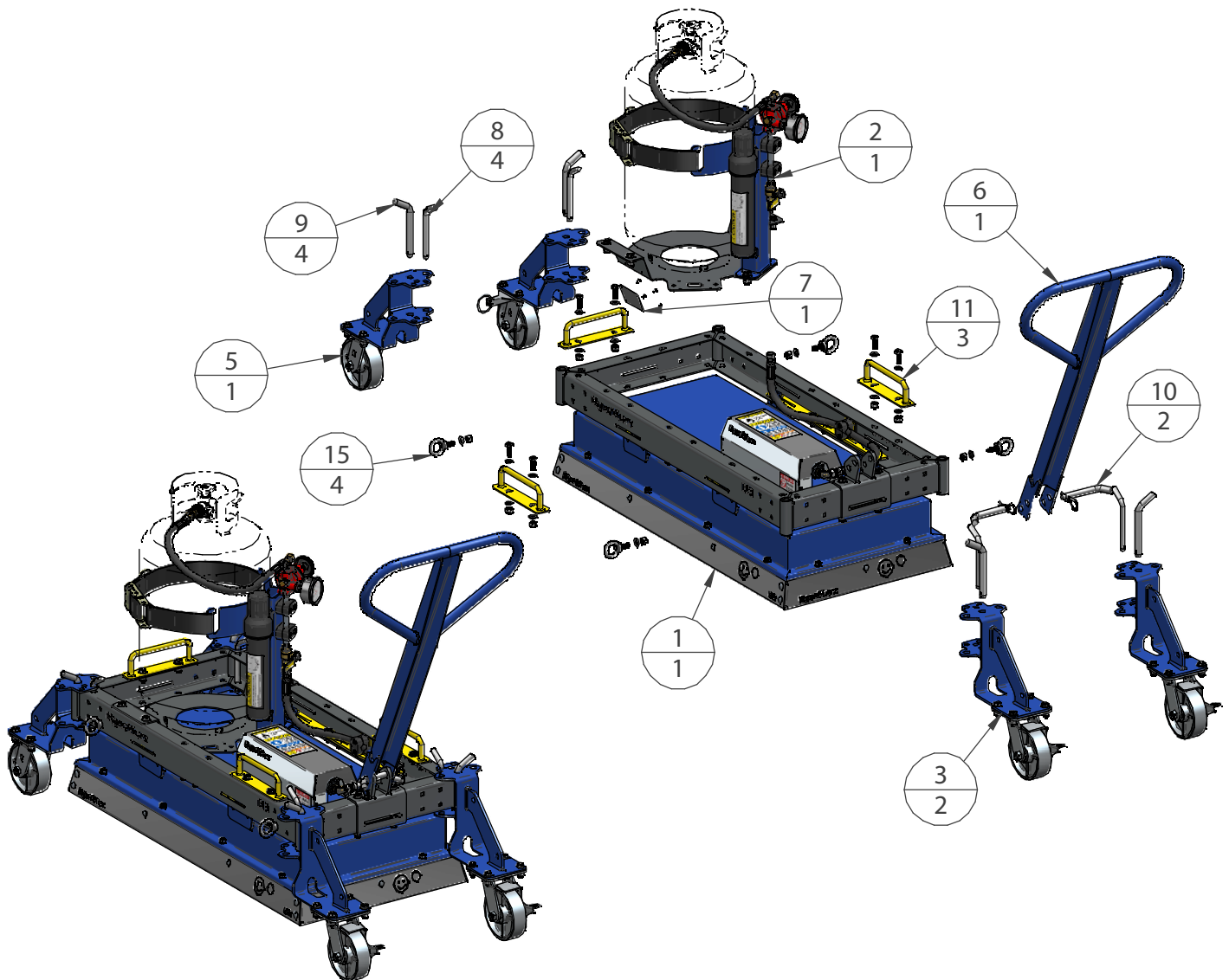

# R3-IR ASSEMBLY

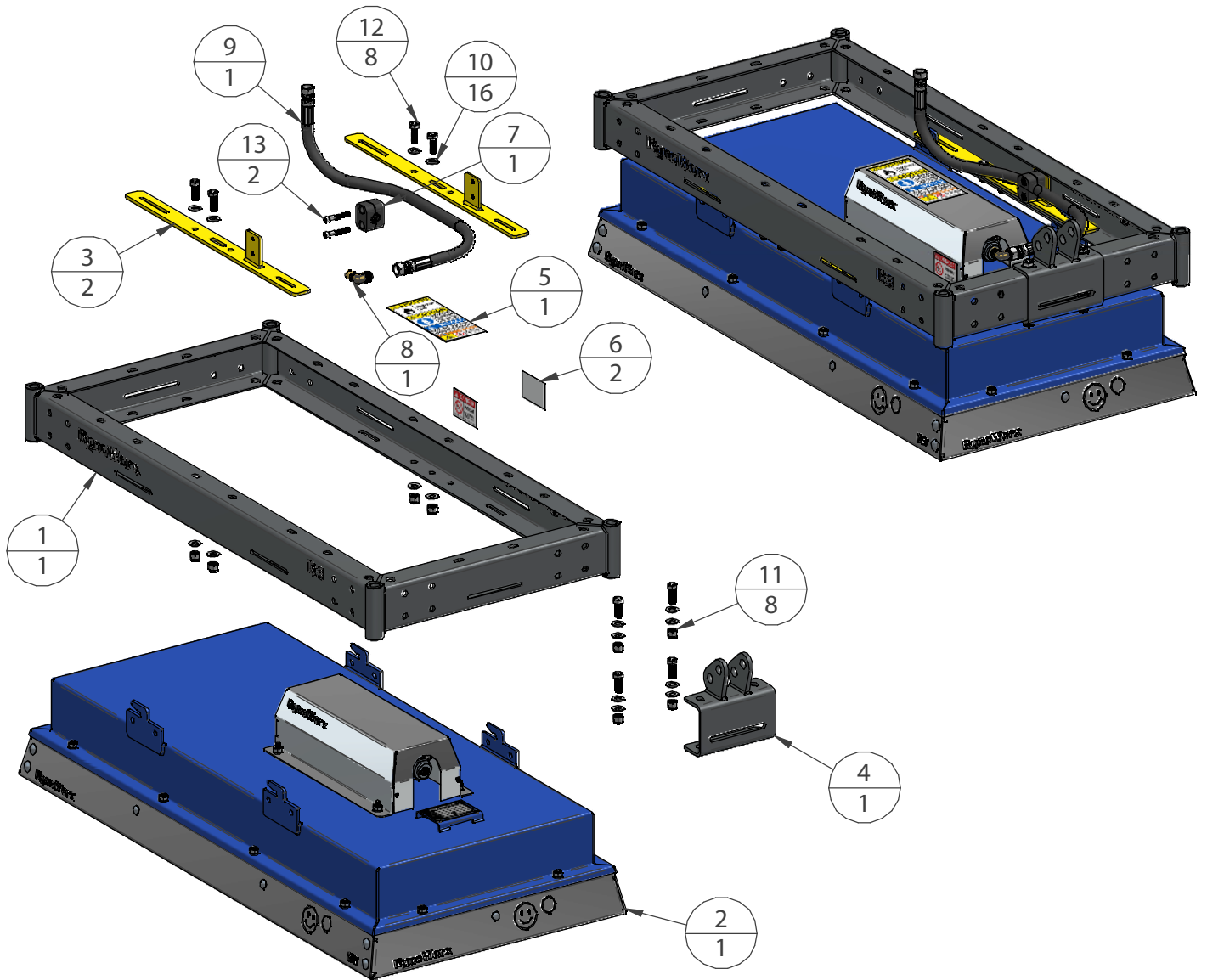

# R3-IR ASSEMBLY

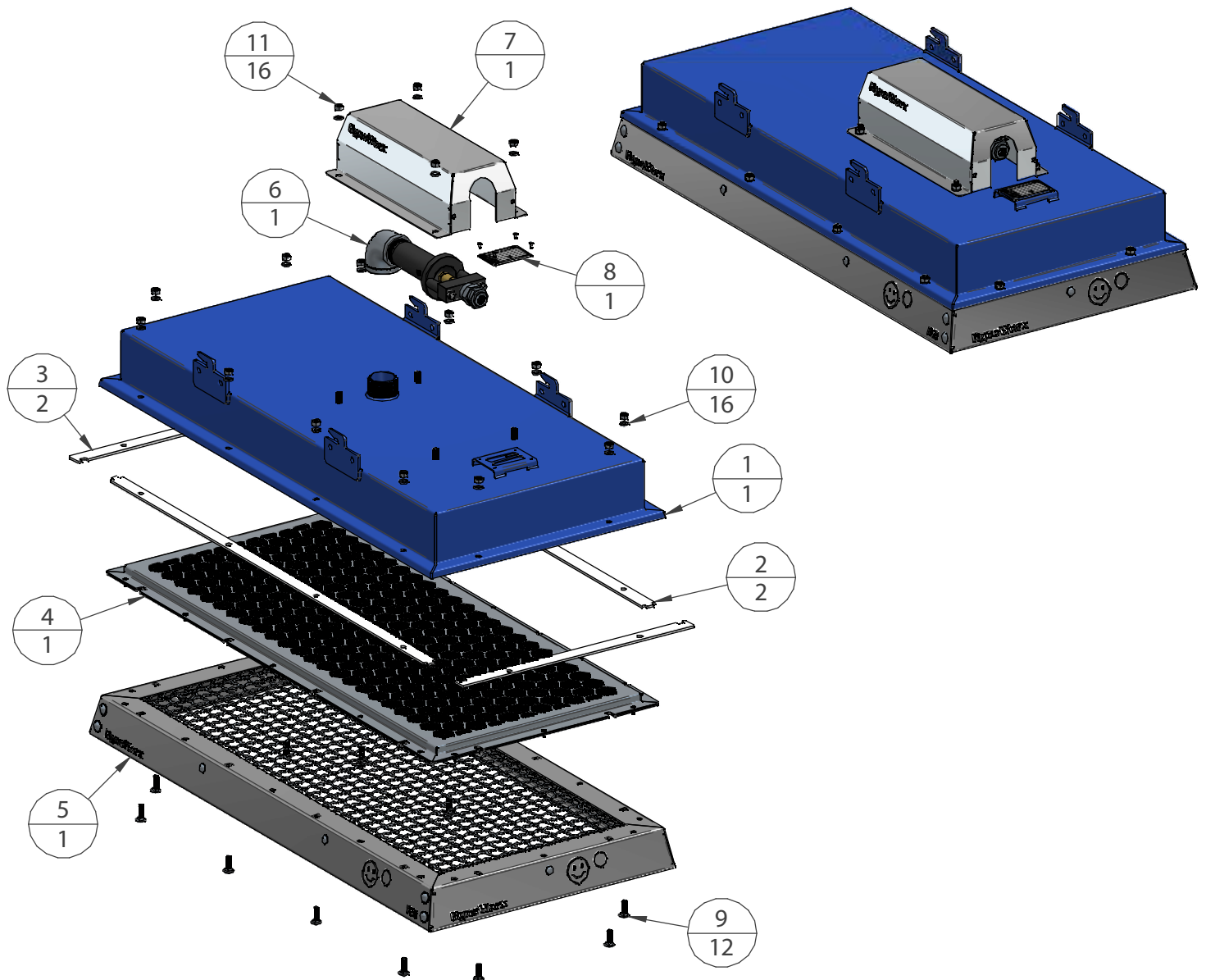

# R3-IR ASSEMBLY

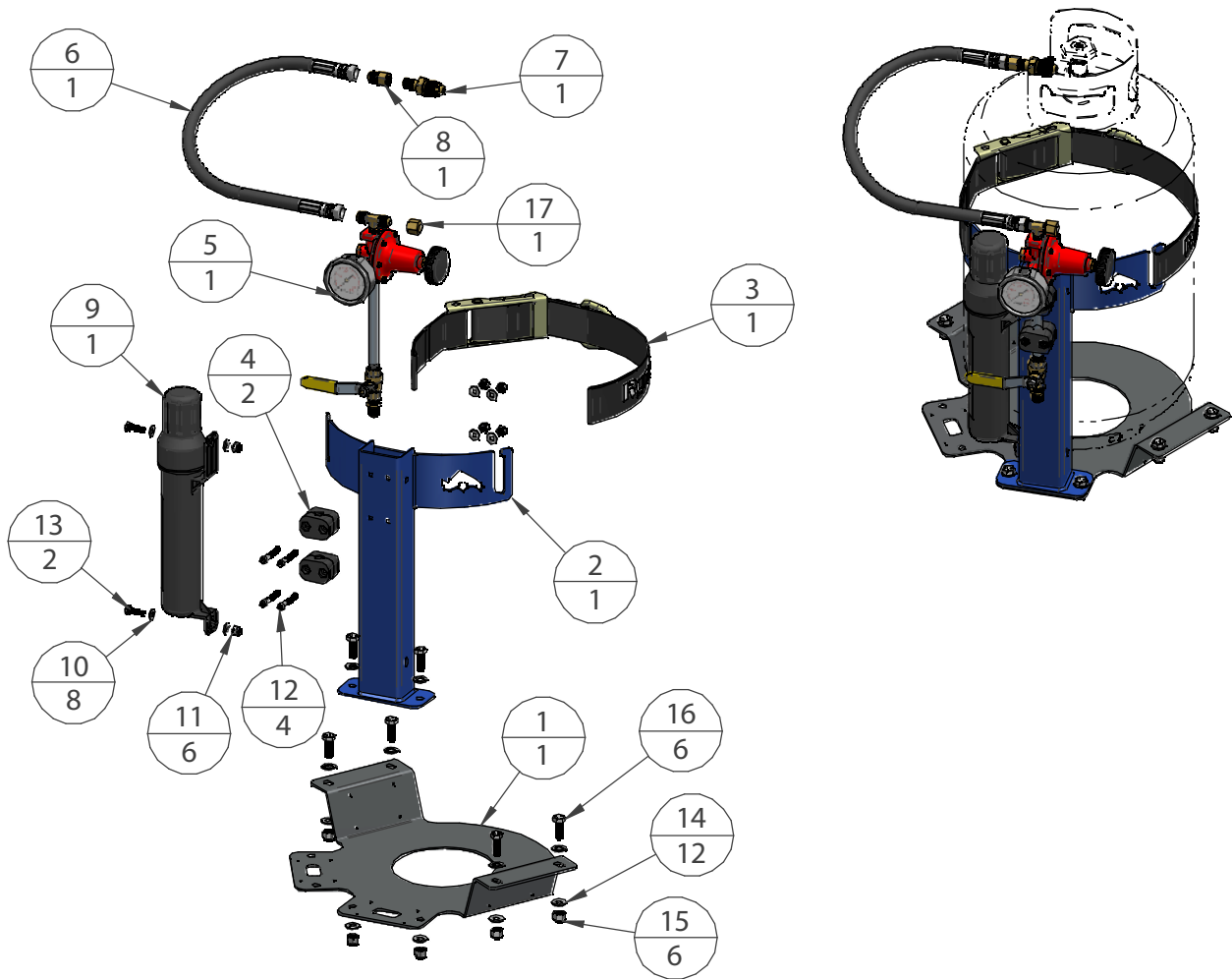

# R3-150 HINGE KIT

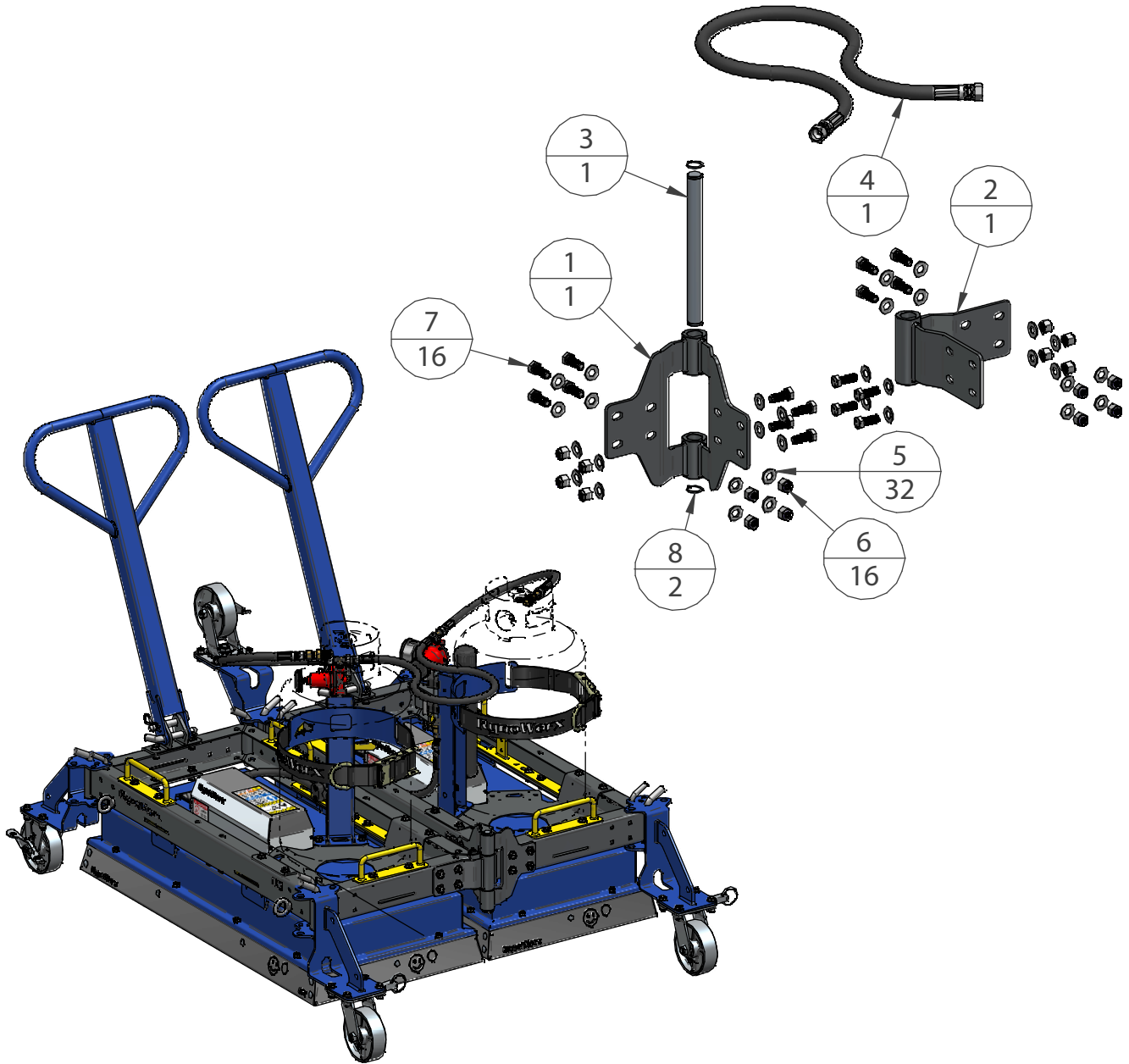

# R4-IR DIMENSIONS

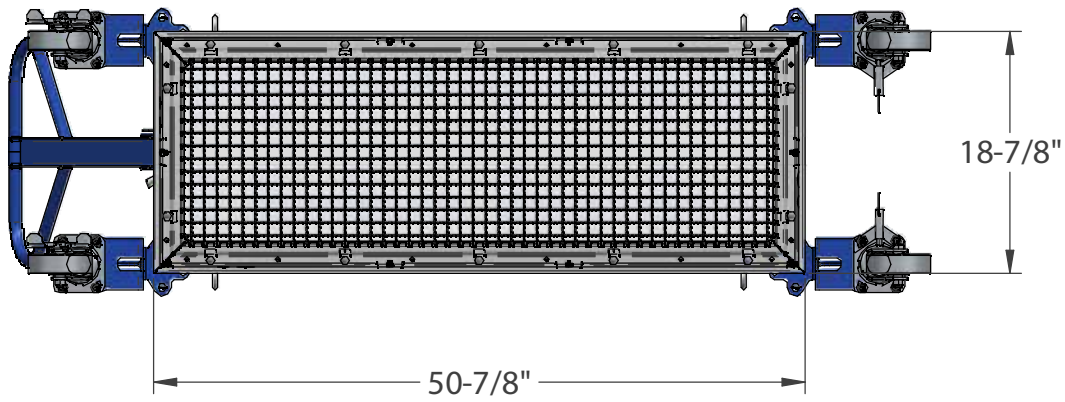
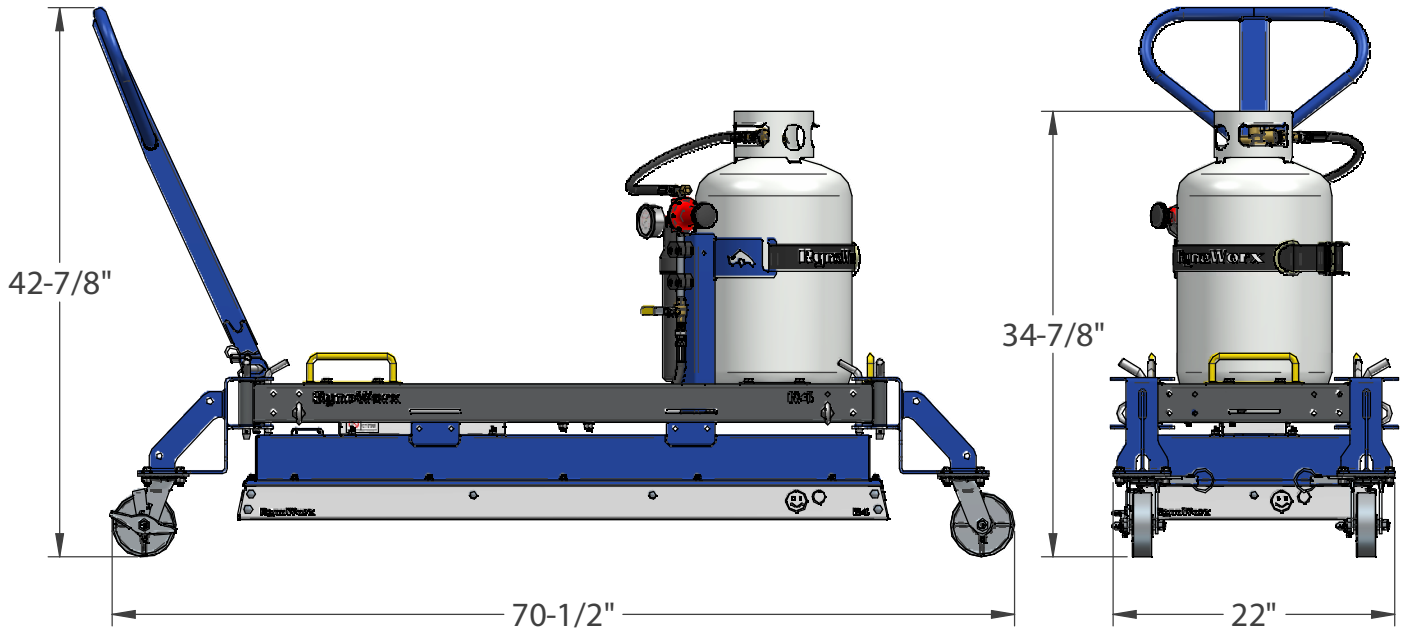



# R4-IR ASSEMBLY

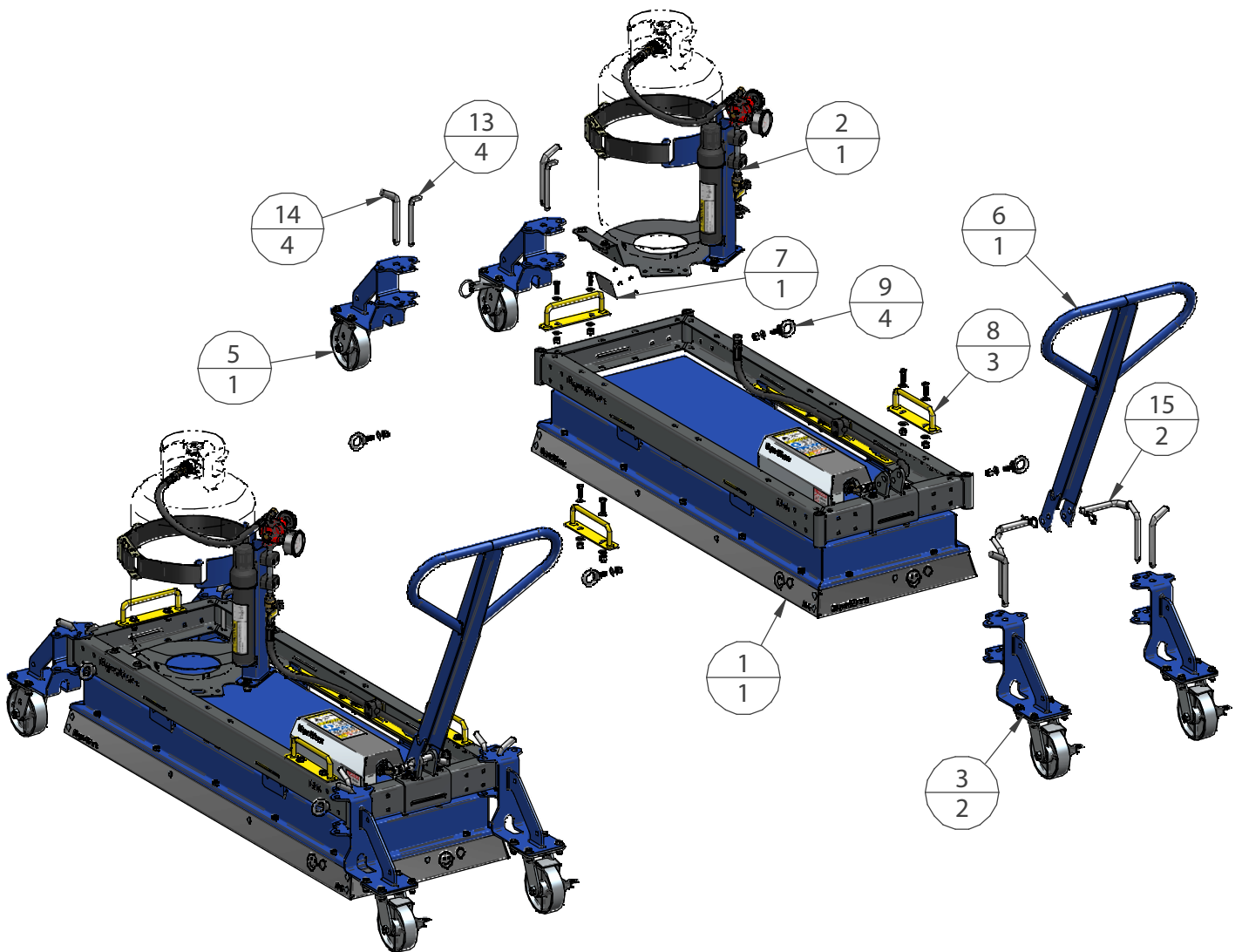

# R4-IR ASSEMBLY

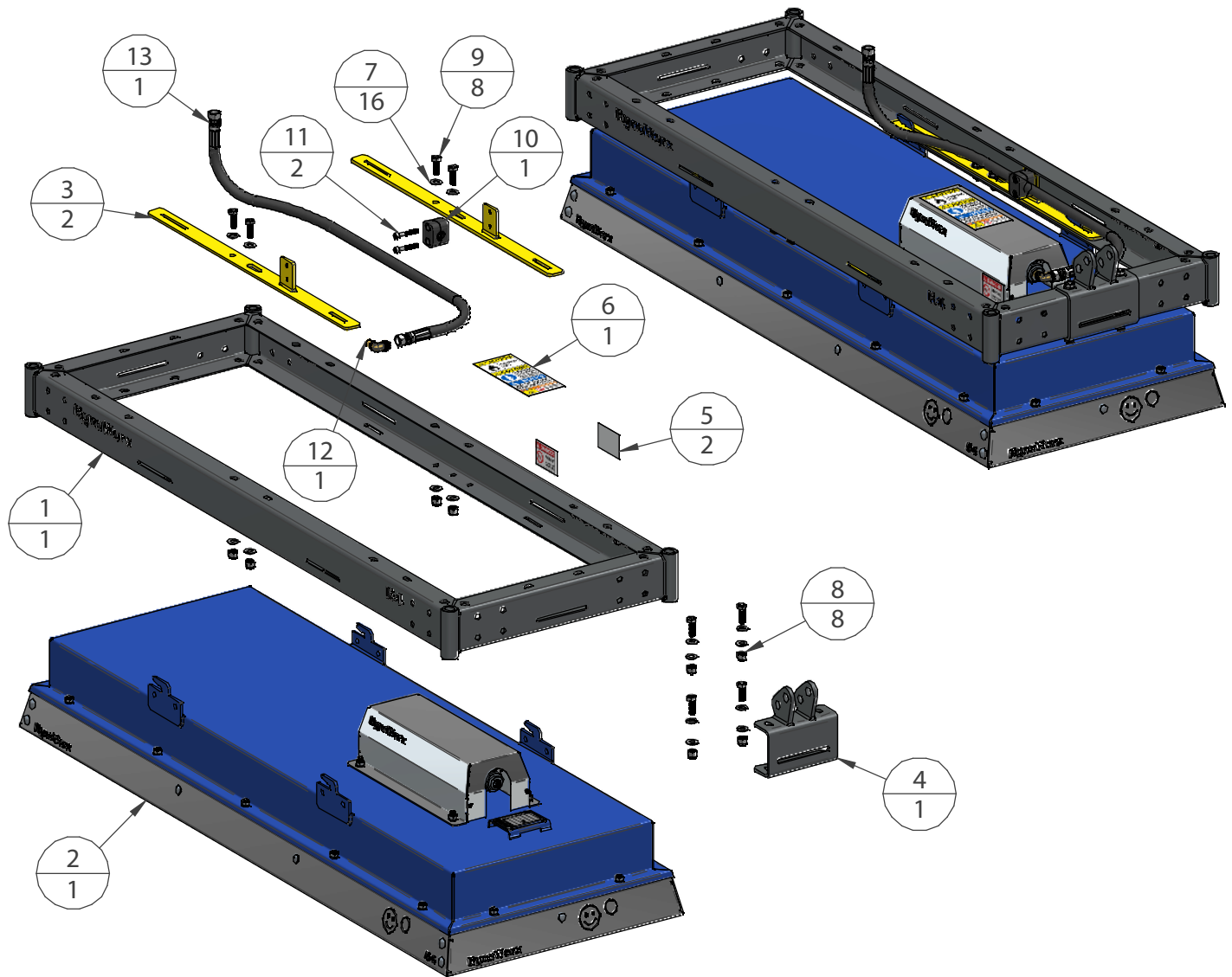

# R4-IR ASSEMBLY

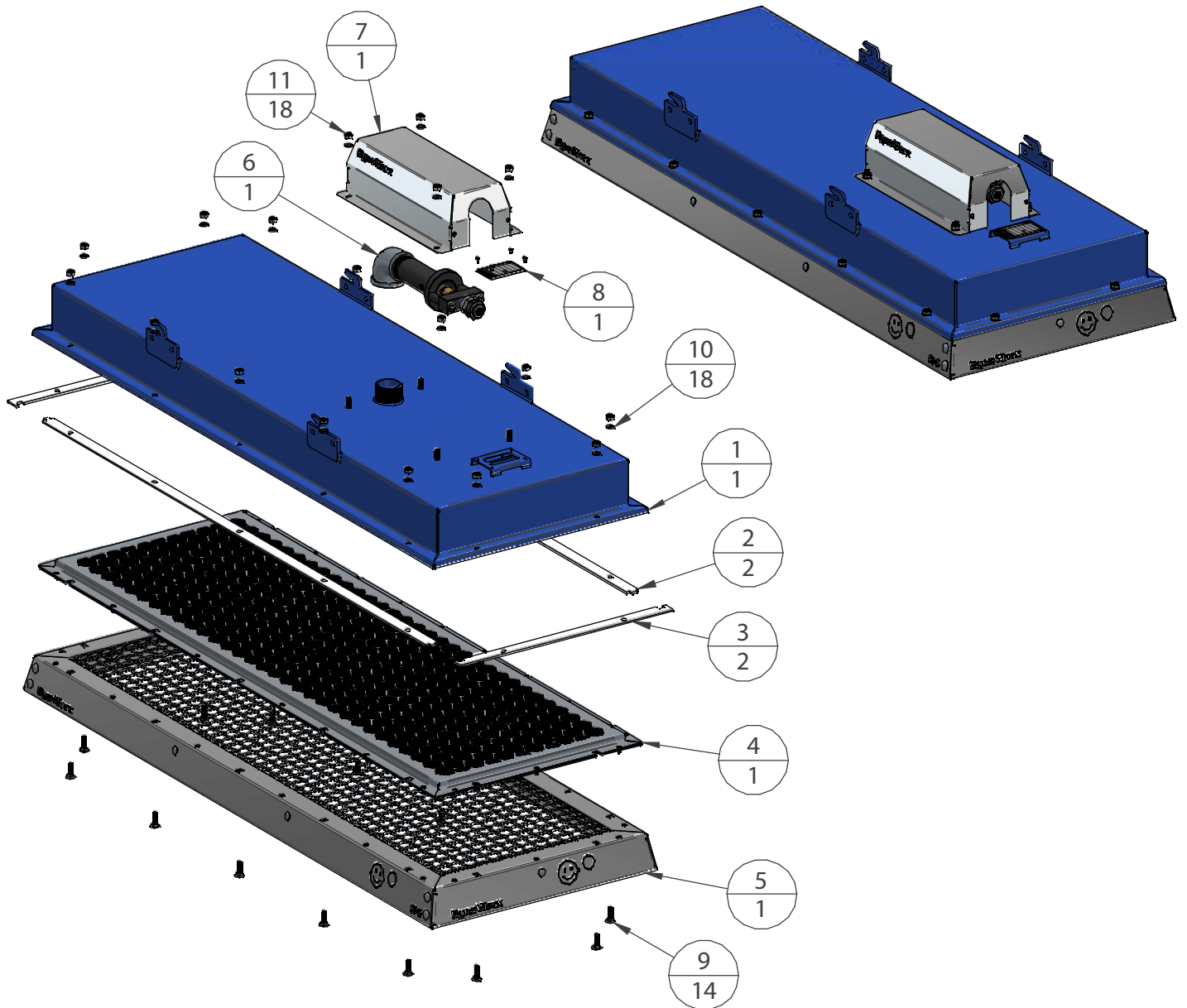

# R4-IR ASSEMBLY

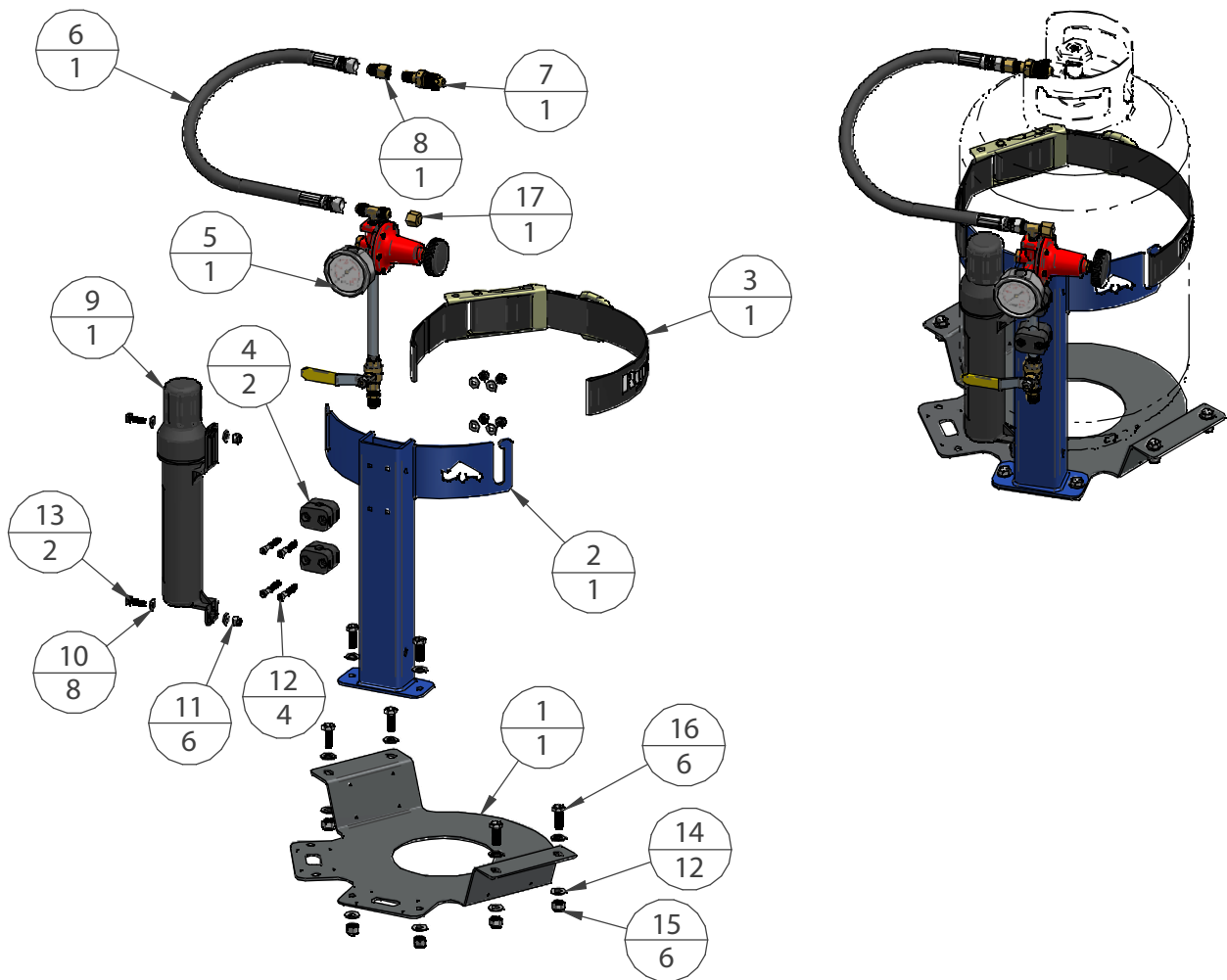

# VENTURI ASSEMBLY

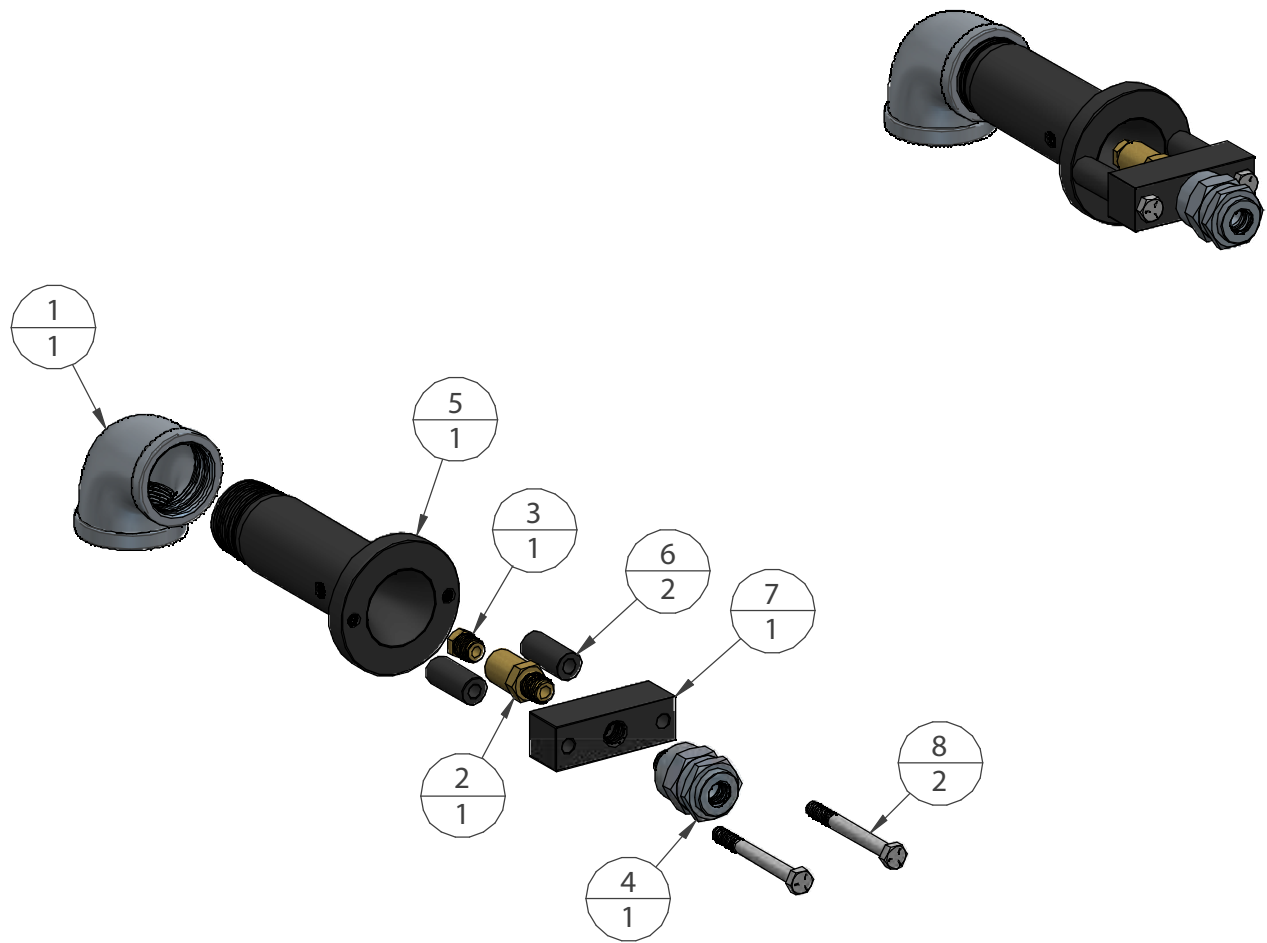

# R4-IR / R3-IR REGULATOR

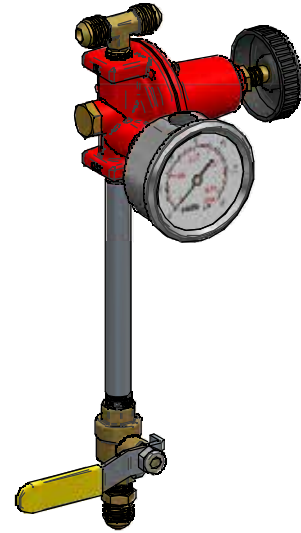
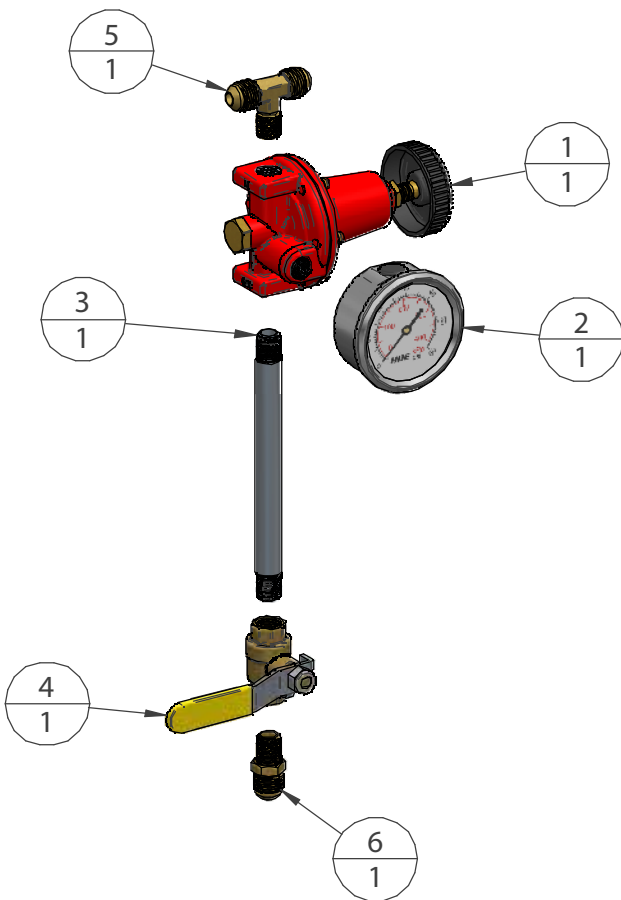

# CASTER WITH BREAK

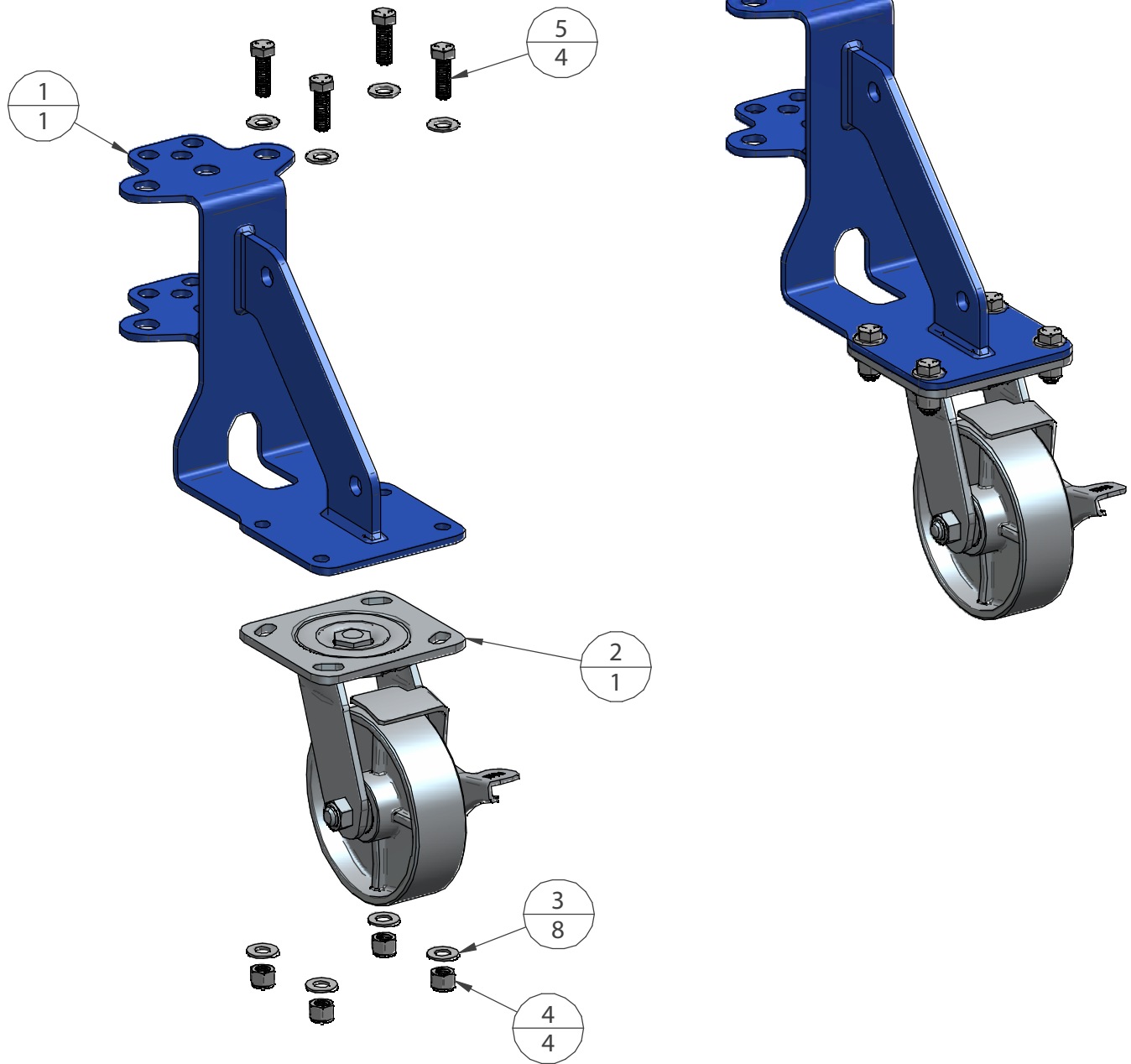

# CASTER NO BREAK

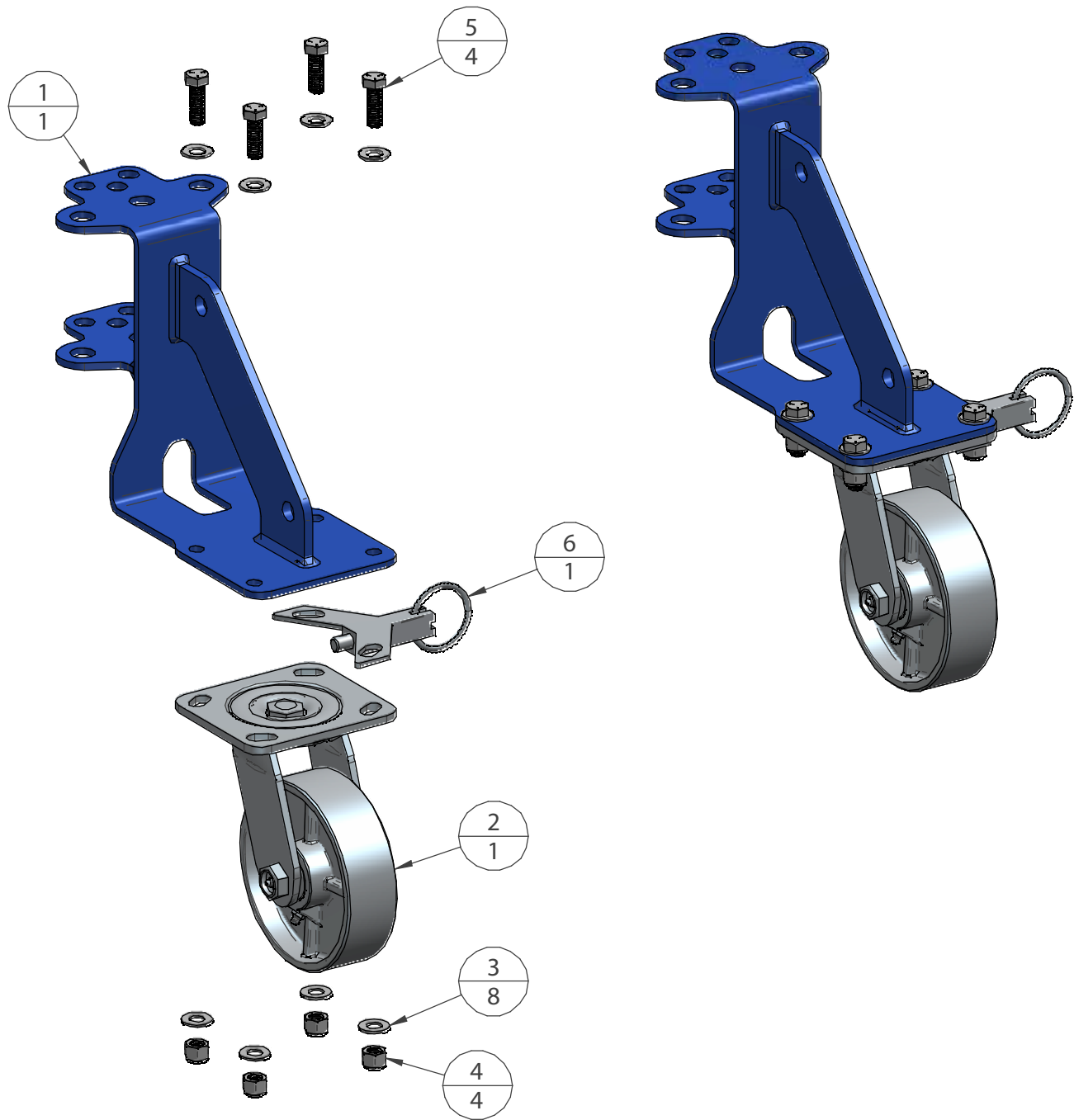



## Product Safety Information Refractory Ceramic Fibre Product



### RISKS:

Possible cancer hazard by inhalation.

Mild mechanical irritation to skin, eyes and upper respiratory system may result from exposure. These effects are usually temporary.

### TO THE EQUIPMENT OWNER:

Please read and carefully follow all instructions provided in the manual regarding your responsibilities in caring for your heating equipment. Contact a professional, qualified service agency for installation, start-up, or service work.

### PRECAUTIONARY MEASURES:

#### Engineering Controls

Use engineering controls such as local exhaust ventilation, point of generation dust collection, down draft workstations, emission controlling tool designs and materials handling equipment designed to minimize airborne fibre emissions.

#### PPE - Skin

Wear personal protective equipment (e.g. gloves), as necessary to prevent skin irritation. Washable or disposable clothing may be used. If possible, do not take unwashed clothing home. If soiled work clothing must be taken home, employees should be informed on best practices to minimize non-work dust exposure (e.g., vacuum clothes before leaving the work area, wash work clothing separately, and rinse washer before washing other household clothes).

#### PPE - Eye

As necessary, wear goggles or safety glasses with side shields.

#### PPE – Respiratory

When engineering and/or administrative controls are insufficient to maintain workplace concentrations below the 0.5 f/cc REG. Wear a NIOSH/MSHA approved respirator.

### FIRST AID MEASURES:

#### Eyes

If eyes become irritated, flush immediately with large amounts of lukewarm water for at least 15 minutes. Eyelids should be held away from the eyeball to ensure thorough rinsing. Do not rub eyes.

#### Skin

If skin becomes irritated, remove soiled clothing. Do not rub or scratch exposed skin. Wash area of contact thoroughly

# PRODUCT SAFETY - REFRACTORY CERAMIC

with soap and water. Using a skin cream or lotion after washing may be helpful.

## **Respiratory Tract**

If respiratory tract irritation develops, move the person to a dust free location.

## **Gastrointestinal**

If gastrointestinal tract irritation develops, move the person to a dust free environment.

***If any of the above irritations persist, seek medical attention immediately.***

**FOR ADDITIONAL PRODUCT INFORMATION AND WORK PRACTICES REFER TO THE MATERIAL SAFETY DATA SHEET.**

Burner Box should be inspected yearly and replaced if it shows signs of cracking and or breaking.

The above cautions should be taken when removing and installing the burner box.

**READ THESE INSTRUCTIONS AND SAVE FOR REFERENCE.**

## Intended Use:

This machine is designed for heating asphalt without burning the existing asphalt oils. The asphalt can be repaired or altered depending on the application.



**WARNING: DO NOT OPERATE THE MACHINE IF A HOSE IS DAMAGED OR IF THERE IS A HOLE IN THE HEATER CARTRIDGE. WHEN CONNECTING YOUR PROPANE TANKS OBSERVE THE FOLLOWING PRECAUTIONS.**

## Tank Connection

1. All connections must be made by a trained worker (check your local regulations).
2. Inspect the infrared heater, regulator, and hoses for defects.
  - Repair or replace any damaged parts.
  - Make sure all hoses and valve connections are clean.
3. Use proper fitting wrenches to make connections.
4. Check for any propane leaks using soapy water solution.
5. Secure the propane cylinder with supplied strap.

## Lighting Procedure

1. Close all ball valves to the individual heaters.
2. Slowly open the cylinder valve and check for gas leaks when the hose line is full of propane, with soapy water or leak detector.
  - When the infrared heater is in use the cylinder valve must be fully opened.
3. Adjust regulator to 35 PSI (High Fire).
4. Ignite the propane gas torch.
5. Slowly open the ball valve and place the torch tip underneath the heater.
  - **DO NOT** point the flame of the torch directly at the ceramic surface. This could damage the ceramic and reduce the life of the cartridge.
  - **DO NOT** attempt to light the heater at the orifice.
6. Repeat step 5 for each heater and adjust the regulator to desired pressure (10 PSI to 35 PSI).

## Heating Procedure

1. Identify and mark areas to be repaired.
  - Be sure to leave 2-3 inches of heated asphalt around the repair to bond with repaired area.
2. Sweep area clean of stones and loose debris.
3. Place heaters over area that needs repair, use only the correct number of heaters to cover the repair area.
  - Turn unused heaters off.
4. Heat area that needs repair with the heaters on high pressure (24-35 PSI).





# IR HEATER OPERATION

- Make sure that surface temperature of the asphalt never exceeds 150C (300F)
  - Time required to soften asphalt to depth of about 2" (0.51mm) will vary depending on the following:
    - ◆ Weather Conditions
    - ◆ Type of Asphalt Mix (Course or Fine, AC Content)
    - ◆ Starting Temperature of the Asphalt
    - ◆ Surfaces Lightness - Dark Surfaces Absorb Radiation Better
    - ◆ Extraneous Materials are Present in Repair Area (ie. Rubberized Crack & Sealant)
5. When asphalt is workable to entire thickness of asphalt or to about 2" (0.51mm) move machine away from work area.
  6. Using an ice scraper and standard construction rake, rework/scarify the asphalt to eliminate all cracks etc. from repair area.
    - Start by re-working at the edges of the repair area. All edges should be straight and square to create uniform looking patches.
    - Allow 2-3 inches of hot asphalt untouched to make the patch seamless with old asphalt.
  7. Once the entire repair area has been reworked, an asphalt rejuvenation agent should be sprayed on the entire patched area at a rate of 1/10<sup>th</sup> of a liter per square meter and be thoroughly mixed into the repair area using an asphalt rake or lute.
  8. Fresh hot mix asphalt should be added as required to the repair area to compensate for voids to fill and level all depressions.
  9. While the material is still hot:
    - First compact the edges of the patch to ensure a seamless smooth edge between the old and new asphalt.
    - Continue compacting inside area until satisfied density is delivered.
  10. The newly patched area should be protected from traffic for a minimum two-hour period or until the asphalt has cooled sufficiently, so that use will not leave any marks.



## Shut off Procedure

1. Close propane tank valve while heater is running to clear propane lines.
2. Close all open ball valves to individual heaters.

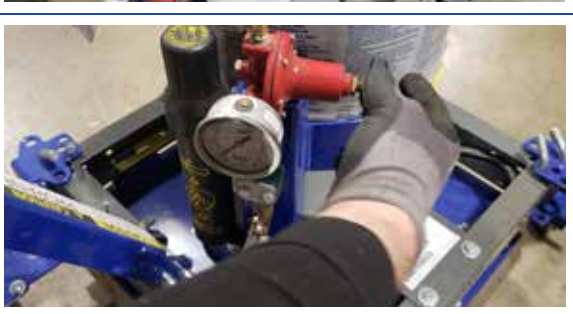
# IR HEATER OPERATION

STEP 1	Place the propane tank(s) and secure them in place.	
STEP 2	Hand tighten the POL fitting into the propane tank.	
STEP 3	Tighten with hand wrench.	
STEP 4	Slowly turn on the gas valve. If opened too fast the safety valve will close. If this happens close tank and start over.	
STEP 5	Test for leaks with soapy mixture..	
STEP 6	Adjust your pressure to 35 PSI to light the heaters	

# IR HEATER OPERATION

STEP 7	Turn each ball valve on individually to ignite the heater(s).	
STEP 8	Place the torch underneath the stainless steel skirt. Ensure the torch is not directed at the ceramic surface.	
STEP 9	Adjust the pressure to the desired pressure 10 PSI to 35 PSI.	

## **Notify your dealer immediately of any malfunction or failure of your equipment.**

Always give model, serial No. and approximate date of your equipment purchase. This information should be recorded and placed on file by the owner at the time of purchase.

Return any damaged parts to dealer for inspection and warranty consideration if in warranty time frame. Order genuine RYNOWORX replacement or repair parts from your authorized RYNOWORX dealer. Use of another manufacturer's parts pay void warranty consideration.

## **Resources Publications**

Contact your RYNOWORX dealer for publications and videos covering safety, operation, service, and repair of your equipment.







## **Rynoworx Training**

For information about on-site or individualized training contact your RYNOWORX dealer.

# IR HEATER CARTRIDGE REPLACEMENT

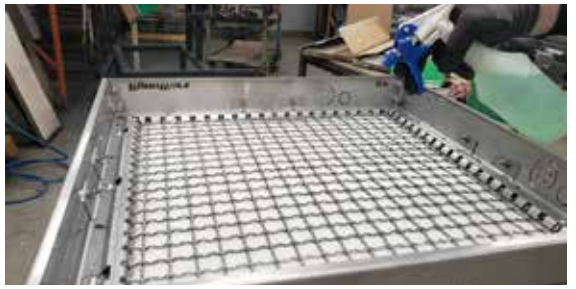

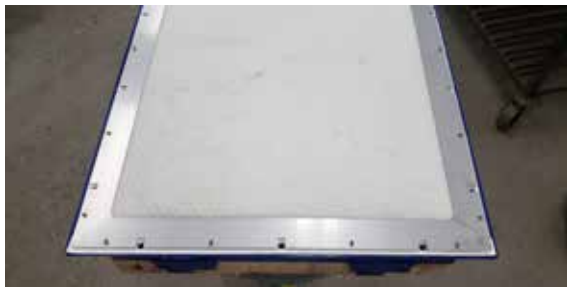
**WARNING: TURN PROPANE VALVE OFF BEFORE SERVICING HEATER. TO AVOID PERSONAL INJURY TURN THE HEATER OFF AND ALLOW TO COOL.**





<b>STEP 1</b>	Remove heater from frame, and place on a flat surface..	
<b>STEP 2</b>	Turn the heater upside down and run water over top of the ceramic. This will eliminate the fibres from travelling through the air. 	
<b>STEP 3</b>	Remove the 5/16 x 1" bolts that hold the heater together.	
<b>STEP 4</b>	Remover the skirt portion of the heater.	
<b>STEP 5</b>	Remover the heater cartridge and gasket, place in a garbage bag.	

# IR HEATER CARTRIDGE REPLACEMENT

STEP 6	Place the first two gaskets.	
STEP 7	Ensure the area that is narrow at bolt hole is towards the outside edge of the heater.	
STEP 8	Finish placing the gaskets so they lay flat and are interlocked.	
STEP 9	Carefully place the ceramic cartridge on top of the gaskets. Make sure the gaskets do not shift.	
STEP 10	Replace the heater skirt on top of the ceramic cartridge.	
STEP 11	Align and place all bolts into place. Hand tighten all bolts. The bolts should be tightened with a torque wrench center bolts first and continuing in a figure 8 pattern . While tightening the bolts make sure that the gaskets do not shift out of place.	

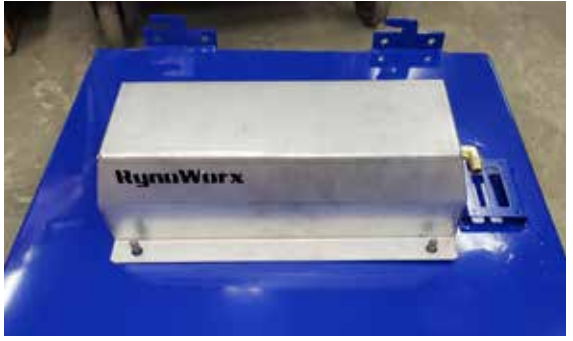

# VENTURI MAINTENANCE

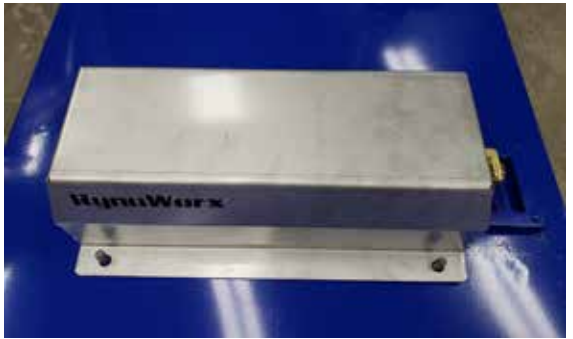
<b>STEP 1</b>	Remove the stainless steel protective cover from the air mixer.	
<b>STEP 2</b>	Remove brass orifice.	
<b>STEP 3</b>	<p>Inspect orifice for any debris. Remove the debris. If the orifice is severely plugged you may need to use compressed air. Check distance to inspirator.</p> <p> DO NOT USE TORCH TIP CLEANERS. THIS MAY INCREASE THE SIZE OR ANGLE OF THE ORIFICE. THIS WILL CAUSE THE HEATER TO PERFORM POORLY.</p>	 <p>Apply pipe sealant on all threads</p>
<b>STEP 4</b>	<p>Re-tighten the orifice holder ensuring there is a small amount of pipe sealant on the threads.</p> <p>Suggested: Clean filter once a year (item 1)</p>	
<b>STEP 5</b>	Re-install the protective hood.	

# TROUBLESHOOTING

<b>PROBLEM</b>	<b>POSSIBLE CAUSE</b>	<b>SOLUTION</b>
<b>HEATERS ARE RUNNING AT DIFFERENT TEMPERATURES</b>	Orifice is plugged or ceramic cartridge is wet	Clean orifice or run heater until it is dry
<b>FLAMES ARE COMING OUT BETWEEN THE UPPER PLENUM AND HEATER SKIRT</b>	Gasket is damaged	Replace gasket
<b>REGULATOR SHOWS PRESSURE BUT THERE IS NO PROPANE AT THE HEATER</b>	Propane hose may be plugged	Replace hoses
<b>HEATER MAKING POPPING NOISE</b>	Ceramic cartridge is damaged	Replace heater cartridge
<b>HEATER WILL NOT LIGHT</b>	Venturi orifice is plugged, very tiny obstruction will also cause issues	Clean orifice
<b>HEATER WILL NOT LIGHT</b>	Gas pressure is too low	Adjust pressure to 15 - 20 PSI
<b>HEATER WILL NOT LIGHT</b>	Tank safety valve is on	Shut off and turn on slowly
<b>HEATER HAS LARGE ORANGE AND YELLOW FLAMES COMING UNDERNEATH</b>	Orifice is missing	Check and replace if needed
<b>GAUGE SHOWS PRESSURE WITH NO PROPANE</b>	Gauge is broken	Replace gauge

**FOR PARTS GO TO [RYNOWORX.COM](http://RYNOWORX.COM) OR CALL 1-855-382-9611**

## **Q: What is Infrared Asphalt Repairs?**

The damaged asphalt is heated so that it becomes soft, then the area is reworked. Rejuvenating emulsion is sprayed on and new asphalt is applied to fill in any voids. The entire area is then compacted with a vibratory compactor to form a seamless patch that is thermally bonded to the surrounding pavement.

## **Q: Will water leak through Infrared Asphalt Repairs?**

No. Thermal bonding of the Infrared asphalt repair with the surrounding pavement makes the repair an integral piece of the pavement.

## **Q: How much will it cost?**

Infrared asphalt repairs are comparable to conventional repairs but your selling price will depend on your specific market.

## **Q: How long does it take?**

Typical Repairs can be done in 20 minutes or less.

## **Q: Is Infrared Patch repair a Green Process?**

Yes. Infrared uses the existing asphalt which leaves little or no wasted material. In fact, Infrared asphalt repairs leaves more than 90% less carbon footprint in our environment as compared to the conventional removal and replace method.

## **Q: Is Infrared restoration too expensive?**

No. Infrared restoration is much more cost effective than traditional full depth patching and mill and pave methods. Consider the savings in manpower, time, machinery and materials by not having to cutout, remove, replace, transport and dispose of large quantities of asphalt. In addition, the result is a neat, clean, seamless patch that is thermally bonded to the surrounding asphalt.

## **Q: Is Infrared restoration only good for small areas?**

No. Infrared can be used economically on large patches and trenches as well. This is achieved by using multiple heats in succession. The larger the machine the more cost effective it will be.

## **Q: Is Infrared restoration permanent?**

Yes. A correctly installed Infrared repair will restore the damaged area to the original condition and useful life of the pavement around the repair. If there is pavement deterioration in the surrounding area it could eventually affect the restoration over time.

## **Q: Can Infrared be used to correct a sub-base problem?**

No. Infrared addresses the asphalt course or the roadway only. Nothing short of excavating and making repairs to the sub-base will correct this problem. Infrared restoration is still the most effective repair to the asphalt once the sub-base problem is corrected.

## **Q: How soon after a repair can you drive over it?**

Once the repaired surface has returned close to normal surface temperature. This is dependent on the original surface material and inclement weather, but even in poor conditions is usually no longer than 30

# IR REPAIR FAQ

minutes.

## **Q: I've seen other infrared repair systems on the market, how is the RYNOWORX system different?**

In short, it's the HEAT! That what our customers tell us. The Patented Technology allows for uniform heat distribution without burning of any of the asphalt. This allows for an even mix temperature throughout the repair area. It is important to have an even temperature both for the scarification process and the compaction process to ensure a quality patch.

For a more detailed description please see our What's different section of our website @ [WWW.RYNOWORX.COM](http://WWW.RYNOWORX.COM).

## **Q: My driveway has sunk in a couple places. Can infrared fix this?**

Settlement is very common. Infrared repair is the best solution for this scenario as long as the sub-base (the course under the asphalt) has stopped settling.

## **Q: My car leaked oil/gas onto my driveway...is it ruined? How can I tell?**

It really depends on how much, and how long! If it is a recent incident you can usually take a good detergent (*like dawn*) and mix with a little water and use a scrub brush with fairly stiff bristles. This should break up the stain. Once completed flush with clean water. If the problem is not taken care of with the above action, you may want to take a pointed object (*like a screwdriver*) and see how deep you can penetrate the asphalt. This will tell you if the binder has been compromised. Where asphalt pavement is a petroleum derivative any gas or oil that saturates into it will neutralize the binder this makes the asphalt hard. If this happens, you cannot do anything to it that will stiffen it up again. The corrective action would be to remove the contaminated asphalt, and repair with a cold patch product, or call an Asphalt Maintenance company that does infrared repairs.

## **Q: Does Infrared repair and reclaiming change the characteristics of the pavement?**

Very slightly, results from lab tests that we have received indicate no differences in physical properties or characteristics of the pavement that was tested. Please keep in mind that pavement characteristics change from geographic location to location. Remember, true infrared is a ray and does not depend on excessive amounts of heat to accomplish its task.

Infrared and conventional repair are similar in the respect that you only achieve good results from taking the time and proper steps to insure a quality job. This includes preparation, proper luteing, and correct compaction. If any of these elements are missing the end result will suffer. We feel that infrared excels in the areas of application, seasonable usage, and the permanence of the repairs.

## **Q: Will Infrared penetrate through multiple lifts?**

YES, when done in steps. If you had a single course of asphalt 3 inches thick, the rays will penetrate through the entire course. If you have a 1" overlay on top of that 3" course, the rays will penetrate only the overlay, or one coarse at a time. The solution is to rake back the softened course, exposing the next course to be heated. The rays can then penetrate the exposed course. Utilizing the proper steps, you can achieve full depth penetration. Of course, in some instances, full depth is not needed nor called for. In the case of many potholes the multiple layers will be exposed to the infrared rays already.

## **Q: Will Infrared penetrate through water?**

NO, infrared rays are unable to penetrate standing water such as you might find in a bird bath. Any standing pools of water should be swept away prior to heating otherwise the asphalt underneath will not be heated. Moisture or dampness will have no effect on penetration.

## **Q: Can infrared be used to correct reflective cracking?**

If the base is not constructed properly or has been affected by water penetration and heavy loads the Infrared process will dress up the area, but the reflective crack will work back through.

## **Q: Can I do repairs in the winter?**

Yes. Repairs can be done year-round in the coldest of temperatures. The outside temperatures will not affect your ability to have a seamless repair but will lengthen the time it takes to heat the asphalt to the full depth of the repair.

## **Q: Does Infrared affect the asphalt binder?**

Two reports explain how infrared will affect the asphalt binder, one from the *University of Auburn (report)*, the other the results of a test performed by the *National Highways Institute (report)*. The reports cover the physical, chemical and rheological properties of the binder following tests using our Infrared joint-heater on a busy 4 lane highway having an overlay done. The application is somewhat more arduous than a repair on a pot-hole on a suburban road because joint-failure on a major highway has significant effects on the highway's life-cycle costs!

## **Q: What do I do with crack filler?**

When Heating Asphalt, it is recommended to put a fine sand such as concrete sand over the crack filler to prevent the crack filler from overheating and starting on fire. After the heating process is complete the material can be removed and disposed.

## **Q: How do I repair a surface imperfection such as segregation and or surface damage?**

When repairing surface asphalt, it is important to remember that you don't need to heat the full surface. You will have a better-looking repair and a happier customer when you heat the asphalt just enough to create a bond and add enough fines to fill in the voids. This will ensure you will not be creating a "patch". With this process you will end up with a spotty look of dark and light areas. Although this will still have a visual difference from any asphalt next to the area in question it will fade quick and in no time you will not see the difference.

# RYNOWORX CONTACT INFORMATION

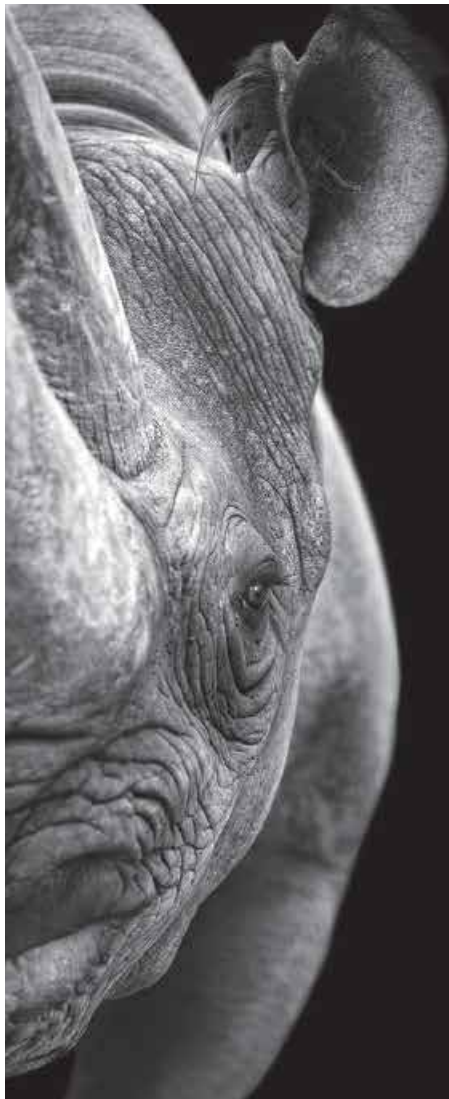

## NEED HELP? WE ARE HERE FOR YOU!

 **Facebook Messenger**  
support@rynoworx.com

 **WhatsApp Messaging**  
519-404-9775

 **Website Chat**  
rynoworx.com/support

 **Email**  
support@rynoworx.com

 **Phone**  
855-382-9611



RECORD YOUR SERIAL PLATE INFORMATION FROM YOUR MACHINE AND RECORD THE DATE OF PURCHASE.

MODEL:			
SERIAL NUMBER			
IR HEATERS			
PART NUMBER		PART NUMBER	
SERIAL NUMBER		SERIAL NUMBER	
PART NUMBER		PART NUMBER	
SERIAL NUMBER		SERIAL NUMBER	